

GUHRING

GROOVING SYSTEMS



NEW

Boring out Grooving Internal threading Broaching Special tools



// FLEXIBLE
// ECONOMICAL
// ACCURATE

GUHRING

GROOVING SYSTEMS

BY **GUHRING**

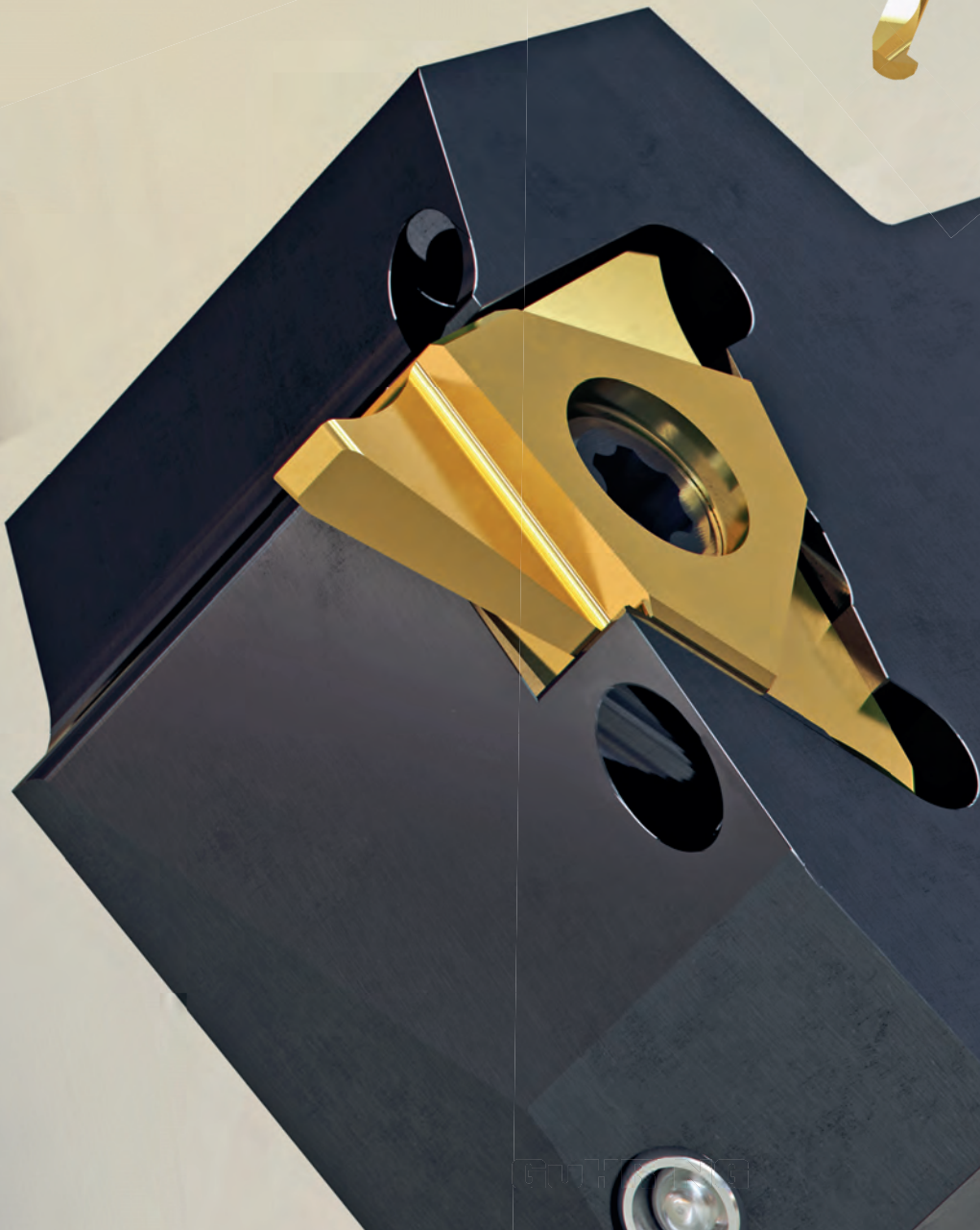

GROOVING SYSTEMS

highest quality and flexibility thanks
to maximum manufacturing depth

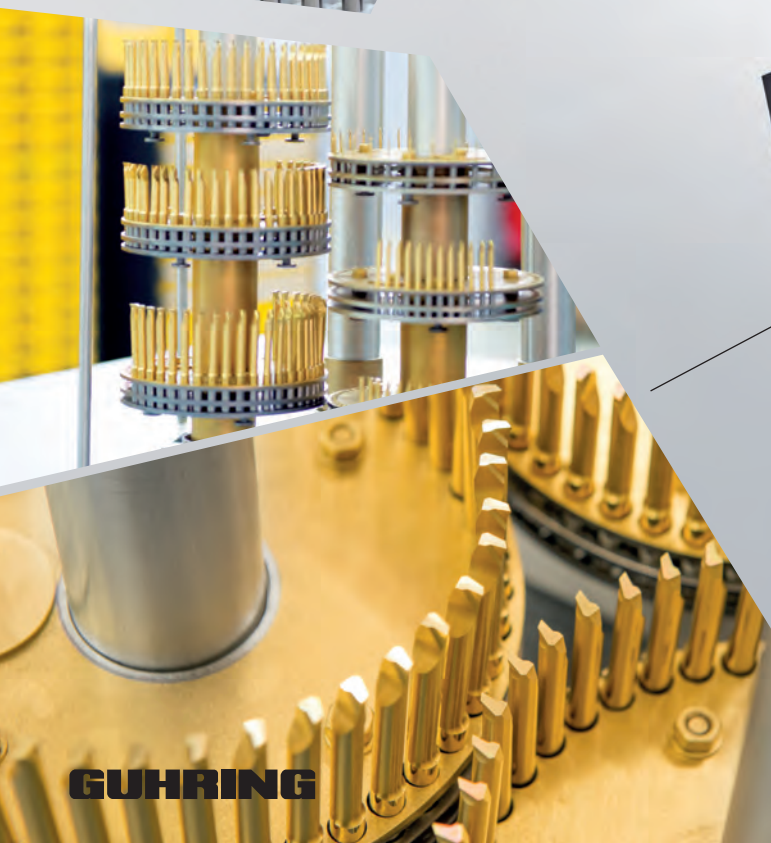

GRINDING – INDEXABLE INSERTS AND CUTTING INSERTS

Complete production on
Guhring built grinding machines

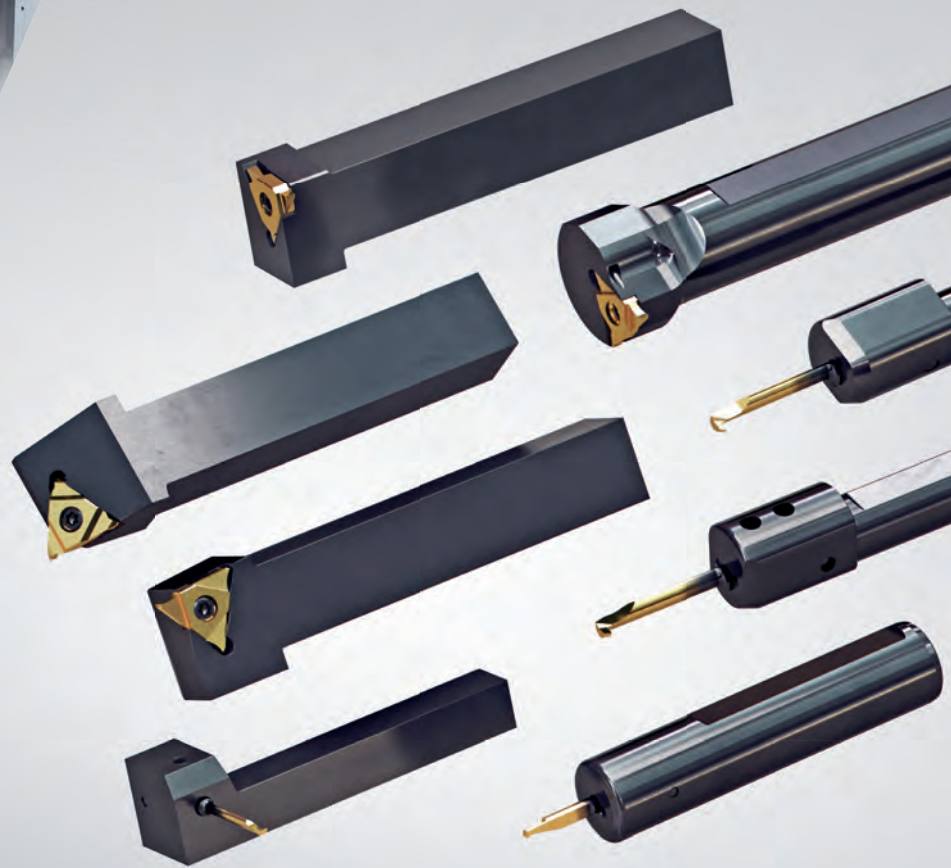

COATING – INDEXABLE INSERTS AND CUTTING INSERTS

// In-house coating on
Guhring built coating systems
// Latest coating technology
and coating types



MILLING/TURNING – HOLDER PRODUCTION



GUHRING'S OWN CARBIDE PRODUCTION

Blanks – Indexable inserts and cutting inserts
Gühring own carbide grades

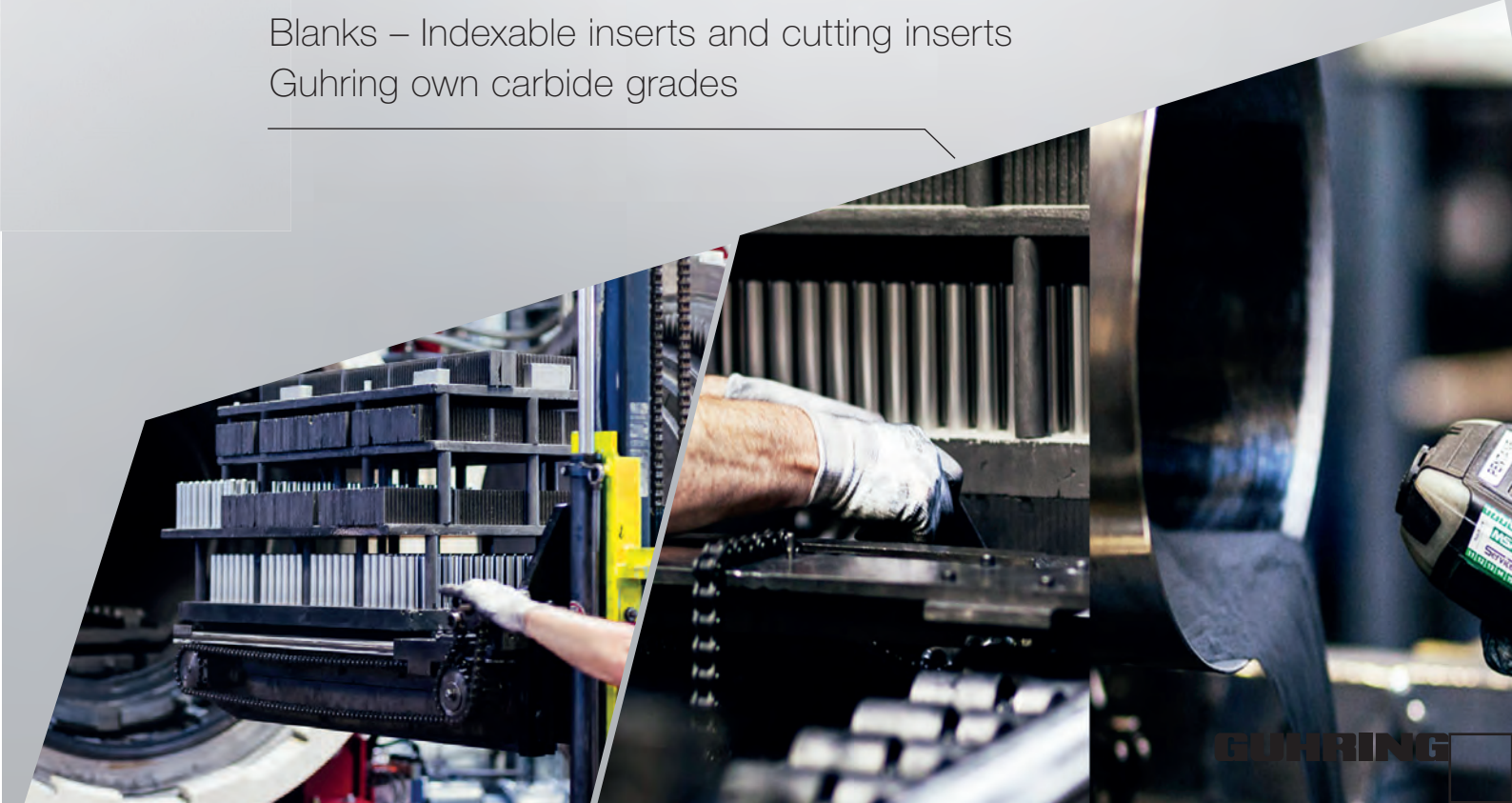

Guhring R&D for innovative tool developments

Highest quality standard world-wide

Pooled expertise under one roof

Exceptionally high manufacturing depth

Machining technology with an edge



GUHRING

Production location
Grooving tools



GUHRING





Dr. Jörg Gühring

President



Oliver Gühring

Sales and Marketing
Director

7000

Employees
world-wide



3500

Employees
Germany



Internal training and further
programme of education



International knowledge transfer thanks
to world-wide exchange programme for
employees



Dietmar Pfränger

R&D, Logistics, Technical and
Production Director



Bernd Schatz

Financial and Commercial
Director



50000

Standard tools

2000

Tool types

55%
45%



■ Standard tools
■ Special tools

Everything from one supplier – comprehensive and global

With a global network of manufacturing sites Guhring develops and produces precision tools for all the important markets. Users from the automotive industry, the aerospace industry or the machine tool and general industry rely on the trend-setting tools manufactured world-wide at the highest level to uniform quality standards.

28

PRODUCTION CENTRES

46

SUBSIDIARIES

47

SERVICE CENTRES



CANADA
Guhring Corp.
sales@guhring.com
www.guhring.com



**USA
BROOKFIELD**
Guhring Inc.
sales@guhring.com
www.guhring.com



**USA
NEW HUDSON**
Guhring Inc.
sales@guhring.com
www.guhring.com



MEXICO
Guhring Mexico S.A. de C.V.
guhringmexico@guhring.com
www.guhring.com.mx



BRAZIL
Guhring Brasil
Kornelias da Silva
veredas@guhring.com
www.guhring.com.br



**SOUTH
AFRICA**
Guhring (South Africa) Pty Ltd
info@guhring.co.za
www.guhring.co.za



SWEDEN
Guhring Sweden AB
info@guhring.se
www.guhring.se



**GREAT
BRITAIN**
Guhring Ltd.
info@guhring.co.uk
www.guhring.co.uk



NETHERLANDS
Guhring Nederland B.V.
info@guhring.nl
www.guhring.nl



BELGIUM
Guhring S.A.
info@guhring.be
www.guhring.be



**SWITZERLAND/
ROTKREUZ**
Guhring Rotkreuz AG
info@guhring.ch
www.guhring.ch



**SWITZERLAND/
AURDORF**
G&E Hiltenswiler AG
maas@guhring.de
www.guhring.de



**ALBSTADT
HEADQUARTER**
Guhring KG
info@guhring.de
www.guhring.de

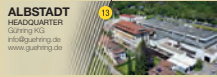

**ALBSTADT
FACTORY 2**
Guhring KG
info@guhring.de
www.guhring.de

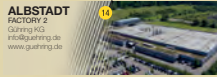

**ALBSTADT
ONSMETTINGEN**
Guhring KG
info@guhring.de
www.guhring.de



SIGMARINGEN
LAC
Guhring KG
info@guhring.de
www.guhring.de



**RAMSTEIN-
MIESENBACH**
Guhring KG
info@guhring.de
www.guhring.de



LEVERKUSEN
Guhring KG
info@guhring.de
www.guhring.de



WEHINGEN
Guhring KG
info@guhring.de
www.guhring.de

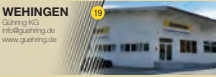

EISENACH
St. Veitwerkzeug KG
info@guhring.de
www.guhring.de



GEISLINGEN
Guhring KG
info@guhring.de
www.guhring.de



MINDELHEIM
LAC
Guhring KG
info@guhring.de
www.guhring.de



NUREMBERG
Holtzler Guhring
Guhring Tools
info@holtzler-guhring.de
www.holtzler-guhring.de



REGENSBURG
Guhring KG
info@guhring.de
www.guhring.de



With innovative technologies Guhring meets specific customer requirements from process proposal to series application of the precision tools – flexibly, promptly, globally. For this, experts are in action internationally looking after customers on site. Production, service and contact persons are available from one supplier world-wide.

Own carbide production Own machine construction
 Own coating plants Highest quality standards world-wide



CHEMNITZ 25
 Dr. Guhring KG
 info@guhring.de
 www.guhring.de

BERLIN 31
 Guhring Präzisionswerkzeuge
 info@guhring.de
 www.guhring.de

RUMANIA 37
 Guhring s.r.l. Romania
 roman@guhring.ro

VIETNAM 43
 Guhring Vietnam LLC
 info@guhring.vn

AUSTRALIA 46
 Guhring Pty. Ltd.
 guhring@guhring.com.au
 www.guhring.com.au

KULMBACH 26
 Guhring KG
 karl@guhring.com
 carbide.com

ZORBAU 32
 Holscher-Guhring GmbH
 info@holscher-guhring.de

HUNGARY 38
 Guhring HKT
 info@hkt.hu
 www.hkt.hu

THAILAND 44
 Guhring (Thailand) Co., Ltd.
 info@thailand.guhring.co.th
 www.guhring.co.th

INDONESIA 50
 PT. Guhring Indonesia
 sales@guhring.co.id
 www.guhring.co.id

MARKT-ERLBACH 27
 Guhring KG
 info@guhring.de
 www.guhring.de

SPAIN 33
 Guhring S.A.S.
 guhring@guhring.es
 www.guhring.es

AUSTRIA 39
 Guhring Ges.m.b.H.
 vertrieb@guhring.at
 www.guhring.at

INDIA 45
 Guhring India Pvt. Ltd.
 info@guhring.in
 www.guhring.in

TAIWAN 31
 Guhring Taiwan Ltd.
 info@guhring.com.tw
 www.guhring.com.tw

TREUEN FACTORY 1 28
 Dr. Guhring KG
 info@guhring.de
 www.guhring.de

ILEBYE UBERMERE 34
 UBERMERE-GUHRING ITALIA S.p.A.
 info@ubermere.it
 www.ubermere.it

POLAND 40
 Guhring Sp. z o.o.
 handel@guhring.pl
 www.guhring.pl

CHINA 46
 Guhring (China) Co., Ltd.
 info@guhringchina.com
 www.guhringchina.com

JAPAN 52
 Guhring Japan Co., Ltd.
 info@guhring.co.jp
 www.guhring.co.jp

TREUEN FACTORY 2 29
 Dr. Guhring KG
 info@guhring.de
 www.guhring.de

ITALY MISSAGLIA 35
 Guhring s.r.l. Unipersonale
 info@guhring.italy.com
 www.guhring.italy.com

CZECH REPUBLIC 41
 Guhring s.r.o.
 info@guhring.cz
 www.guhring.cz

TURKEY 47
 Guhring (Turkey) Co., Ltd.
 guhring@guhring.com.tr
 www.guhring.com.tr

KOREA 53
 Guhring Korea Co., Ltd.
 info@guhring.co.kr
 www.guhring.co.kr

TREUEN FACTORY 3 30
 Dr. Guhring KG
 info@guhring.de
 www.guhring.de

FRANCE 36
 Guhring France S.A.R.L.
 info@guhring-france.com

DENMARK 42
 Guhring A/S
 info@guhring.dk
 www.guhring.dk

RUSSIA 48
 Guhring (Russia) Co., Ltd.
 info@guhring.ru
 www.guhring.ru

GUHRING



GROOVING SYSTEMS

Highest quality and flexibility
thanks to maximum manufacturing depth.
All from one supplier.



SYSTEM 104

Micro-precision tools from Ø 0.7 mm from page 15

Tool holder..... from page 16

Cutting inserts..... from page 19

Broaching from Ø 1.5 mm..... from page 15

Tool holder..... from page 48

Cutting inserts..... from page 49



SYSTEM 106

Micro-precision tools from Ø 6 mm..... from page 53

Tool holder..... from page 54

Cutting inserts..... from page 56

Broaching from Ø 6 mm..... from page 53

Tool holder..... from page 71

Cutting inserts..... from page 72



SYSTEM 305

Grooving and parting off..... from page 75

Tool holder..... from page 76

Indexable inserts..... from page 85

Navigator & Technical information..... from page 94

Accessories..... from page 98

Special solutions..... from page 100

Article no. index..... from page 104

104





SYSTEM 104

MICRO-PRECISION TOOLS

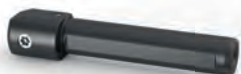

Round shank
clamping screw top
page 16



Round shank
clamping screw lateral
page 17



Square shank
clamping screw lateral
page 18



Round shank
broaching
page 48

Tool holder

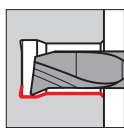

Boring out
and profiling
from page 20

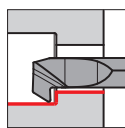

Back boring
and profiling
from page 31

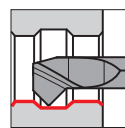

Boring out
and chamfering
page 33

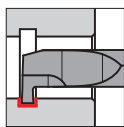

Internal grooving,
straight slots
page 34

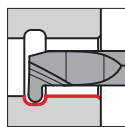

Internal grooving,
full radius slots
page 36

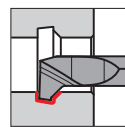

Internal grooving
and chamfering
page 37

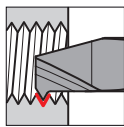

Internal threading
from page 43

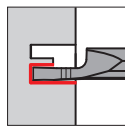

Axial grooving bores
from page 38

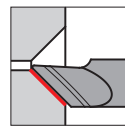

Axial chamfering
bores
page 42

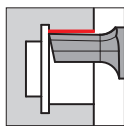

Broaching
from page 49

Cutting inserts from hole- \varnothing 0.7 mm



Round shank holder, clamping screw top

- Shank-Ø 10-25, for cutting insert type 104
- with internal coolant delivery

Type GB 104

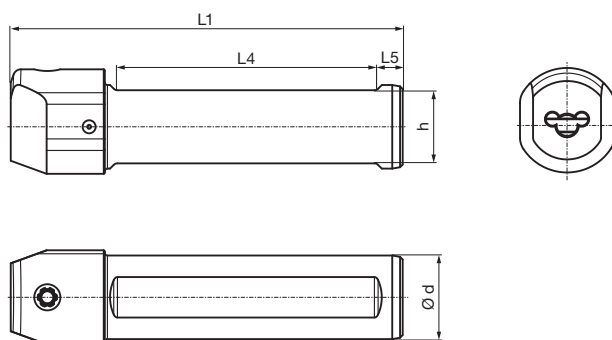

Article no. **25000**

Code no.	Description	d	h	L1	L4	L5
		mm	mm	mm	mm	mm
4.001	GB104.0010.075.00.15.N.IK	10.00	9.00	75.00	50.00	5.00
4.002	GB104.0012.075.00.15.N.IK	12.00	11.00	75.00	50.00	5.00
4.003	GB104.0016.075.00.15.N.IK	16.00	14.00	75.00	50.00	5.00
4.004	GB104.0020.090.00.15.N.IK	20.00	18.00	90.00	55.00	5.00
4.005	GB104.0022.090.00.15.N.IK	22.00	20.00	90.00	55.00	5.00
4.006	GB104.0025.100.00.15.N.IK	25.00	23.00	100.00	55.00	5.00

Spare parts

Article no.	Clamping screw	Tightening torque
25900		Nm
Code 6.000	M6x7.5x15IP	4-4.5

Article no.	Torx-Plus Wrench
25904	
Code 15.000	T15IP T-handle

Round shank holder, clamping screw lateral

- Shank-Ø 10-25, for cutting insert type 104
- with internal coolant delivery

Type GB 104

System 104

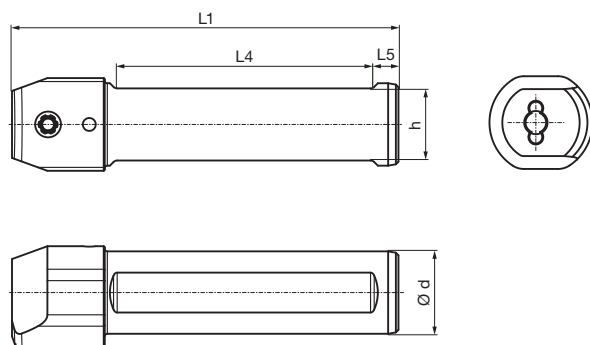
Article no. **25001**

Code no.	Description	d	h	L1	L4	L5
		mm	mm	mm	mm	mm
4.001	GB104.0010.075.00.15.N.IK.90	10.00	9.00	75.00	50.00	5.00
4.002	GB104.0012.075.00.15.N.IK.90	12.00	11.00	75.00	50.00	5.00
4.003	GB104.0016.075.00.15.N.IK.90	16.00	14.00	75.00	50.00	5.00
4.004	GB104.0020.090.00.15.N.IK.90	20.00	18.00	90.00	55.00	5.00
4.005	GB104.0022.090.00.15.N.IK.90	22.00	20.00	90.00	55.00	5.00
4.006	GB104.0025.100.00.15.N.IK.90	25.00	23.00	100.00	55.00	5.00

Spare parts

Article no.	Clamping screw	Tightening torque
25900		Nm
Code 6.000	M6x7.5x15IP	4-4.5

Article no.	Torx-Plus Wrench
25904	
Code 15.000	T15IP T-handle



Square shank holder, 90° offset

- Shank 10x10 - 16x16, for cutting insert type 104
- without internal coolant delivery

Type GH 104

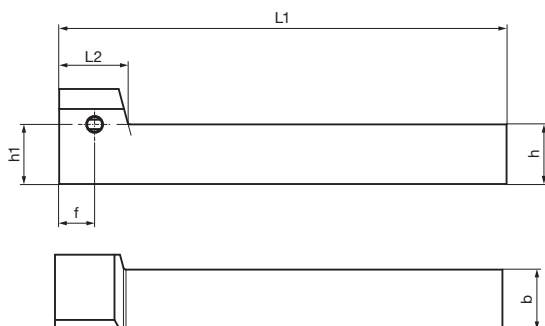

Right hand version shown
Left hand version mirror image



Article no. **25002**

version right-hand

Code no.	Description	b	h	h1	f	L1	L2
		mm	mm	mm	mm	mm	mm
4.002	GH104.1010.090.90.15.R	10.00	10.00	10.00	9.50	90.00	18.500
4.003	GH104.1212.090.90.15.R	12.00	12.00	12.00	9.50	90.00	18.500
4.004	GH104.1616.120.90.15.R	16.00	16.00	16.00	9.50	120.00	18.500

Article no. **25003**

version left-hand

Code no.	Description	b	h	h1	f	L1	L2
		mm	mm	mm	mm	mm	mm
4.002	GH104.1010.090.90.15.L	10.00	10.00	10.00	9.50	90.00	18.500
4.003	GH104.1212.090.90.15.L	12.00	12.00	12.00	9.50	90.00	18.500
4.004	GH104.1616.120.90.15.L	16.00	16.00	16.00	9.50	120.00	18.500

Spare parts

Article no.	Clamping screw	Tightening torque
25900		Nm
Code 6.000	M6x7.5x15IP	4-4.5

Article no.	Torx-Plus Wrench
25904	
Code 15.000	T15IP T-handle

104

CUTTING INSERTS



Cutting insert for boring out and profiling

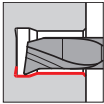

• from hole-Ø 0.7, radial free 23°

for tool holders type GH104/GB104 see from page 16

Tool material	Solid carbide			
Type	GT 104	GT 104	GT 104	GT 104
Surface				
	TiN	TiAlN-nanoA	TiCN	bright

GUHRING NAVIGATOR

Cutting data page 94

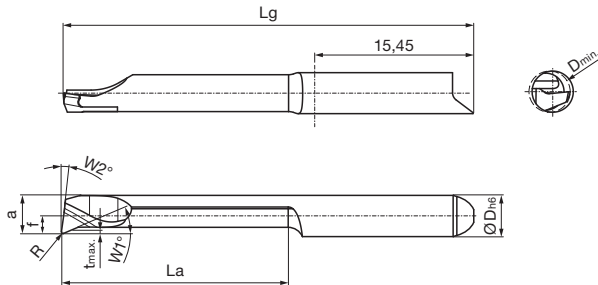

Right hand version shown
Left hand version mirror image

Article no.	25050	25052	25054	25056
Cutting direction				

Code no.	Description	D min	R	W1	W2	f	a	t max	La	Lg	D h6
		mm	mm	°	°	mm	mm	mm	mm	mm	mm
4.001	GT104.2306.005.03.07.R	0.70	0.05	23	8	1.95	0.60	0.05	3.00	25.00	4.00
4.002	GT104.2309.005.04.10.R	1.00	0.05	23	8	1.95	0.90	0.10	4.00	25.00	4.00
4.003	GT104.2309.005.07.10.R	1.00	0.05	23	8	1.95	0.90	0.10	7.00	25.00	4.00
4.004	GT104.2314.005.04.15.R	1.50	0.05	23	8	1.95	1.40	0.15	4.00	25.00	4.00
4.005	GT104.2314.005.07.15.R	1.50	0.05	23	8	1.95	1.40	0.15	7.00	25.00	4.00
4.006	GT104.2314.005.12.15.R	1.50	0.05	23	8	1.95	1.40	0.15	12.00	30.00	4.00
4.007	GT104.2314.010.04.15.R	1.50	0.10	23	8	1.95	1.40	0.15	4.00	25.00	4.00
4.008	GT104.2314.010.07.15.R	1.50	0.10	23	8	1.95	1.40	0.15	7.00	25.00	4.00
4.009	GT104.2314.010.12.15.R	1.50	0.10	23	8	1.95	1.40	0.15	12.00	30.00	4.00
4.010	GT104.2319.005.04.20.R	2.00	0.05	23	8	1.95	1.90	0.15	4.00	25.00	4.00
4.011	GT104.2319.005.07.20.R	2.00	0.05	23	8	1.95	1.90	0.15	7.00	25.00	4.00
4.012	GT104.2319.005.12.20.R	2.00	0.05	23	8	1.95	1.90	0.15	12.00	30.00	4.00
4.013	GT104.2319.005.17.20.R	2.00	0.05	23	8	1.95	1.90	0.15	17.00	35.00	4.00
4.014	GT104.2319.010.04.20.R	2.00	0.10	23	8	1.95	1.90	0.15	4.00	25.00	4.00
4.015	GT104.2319.010.07.20.R	2.00	0.10	23	8	1.95	1.90	0.15	7.00	25.00	4.00
4.016	GT104.2319.010.12.20.R	2.00	0.10	23	8	1.95	1.90	0.15	12.00	30.00	4.00
4.017	GT104.2319.010.17.20.R	2.00	0.10	23	8	1.95	1.90	0.15	17.00	35.00	4.00
4.018	GT104.2319.015.04.20.R	2.00	0.15	23	8	1.95	1.90	0.15	4.00	25.00	4.00
4.019	GT104.2319.015.07.20.R	2.00	0.15	23	8	1.95	1.90	0.15	7.00	25.00	4.00
4.020	GT104.2319.015.12.20.R	2.00	0.15	23	8	1.95	1.90	0.15	12.00	30.00	4.00
4.021	GT104.2319.015.17.20.R	2.00	0.15	23	8	1.95	1.90	0.15	17.00	35.00	4.00
4.022	GT104.2326.005.07.30.R	3.00	0.05	23	8	1.95	2.60	0.20	7.00	25.00	4.00
4.023	GT104.2326.005.12.30.R	3.00	0.05	23	8	1.95	2.60	0.20	12.00	30.00	4.00
4.024	GT104.2326.005.17.30.R	3.00	0.05	23	8	1.95	2.60	0.20	17.00	35.00	4.00
4.025	GT104.2326.005.22.30.R	3.00	0.05	23	8	1.95	2.60	0.20	22.00	40.00	4.00
4.026	GT104.2326.010.07.30.R	3.00	0.10	23	8	1.95	2.60	0.20	7.00	25.00	4.00
4.027	GT104.2326.010.12.30.R	3.00	0.10	23	8	1.95	2.60	0.20	12.00	30.00	4.00
4.028	GT104.2326.010.17.30.R	3.00	0.10	23	8	1.95	2.60	0.20	17.00	35.00	4.00
4.029	GT104.2326.010.22.30.R	3.00	0.10	23	8	1.95	2.60	0.20	22.00	40.00	4.00
4.030	GT104.2326.020.07.30.R	3.00	0.20	23	8	1.95	2.60	0.20	7.00	25.00	4.00
4.031	GT104.2326.020.12.30.R	3.00	0.20	23	8	1.95	2.60	0.20	12.00	30.00	4.00
4.032	GT104.2326.020.17.30.R	3.00	0.20	23	8	1.95	2.60	0.20	17.00	35.00	4.00
4.033	GT104.2326.020.22.30.R	3.00	0.20	23	8	1.95	2.60	0.20	22.00	40.00	4.00
4.034	GT104.2337.005.12.40.R	4.00	0.05	23	8	1.70	3.70	0.30	12.00	30.00	4.00
4.035	GT104.2337.005.17.40.R	4.00	0.05	23	8	1.70	3.70	0.30	17.00	35.00	4.00
4.036	GT104.2337.005.22.40.R	4.00	0.05	23	8	1.70	3.70	0.30	22.00	40.00	4.00
4.037	GT104.2337.005.27.40.R	4.00	0.05	23	8	1.70	3.70	0.30	27.00	45.00	4.00
4.038	GT104.2337.005.32.40.R	4.00	0.05	23	8	1.70	3.70	0.30	32.00	50.00	4.00
4.039	GT104.2337.015.12.40.R	4.00	0.15	23	8	1.70	3.70	0.30	12.00	30.00	4.00
4.040	GT104.2337.015.17.40.R	4.00	0.15	23	8	1.70	3.70	0.30	17.00	35.00	4.00
4.041	GT104.2337.015.22.40.R	4.00	0.15	23	8	1.70	3.70	0.30	22.00	40.00	4.00
4.042	GT104.2337.015.27.40.R	4.00	0.15	23	8	1.70	3.70	0.30	27.00	45.00	4.00



		Article no.		25050	25052	25054	25056				
		Cutting direction		(R)	(R)	(R)	(R)				
Code no.	Description	D min	R	W1	W2	f	a	t max	La	Lg	D h6
		mm	mm	°	°	mm	mm	mm	mm	mm	mm
4.043	GT104.2337.015.32.40.R	4.00	0.15	23	8	1.70	3.70	0.30	32.00	50.00	4.00
4.044	GT104.2337.025.12.40.R	4.00	0.25	23	8	1.70	3.70	0.30	12.00	30.00	4.00
4.045	GT104.2337.025.17.40.R	4.00	0.25	23	8	1.70	3.70	0.30	17.00	35.00	4.00
4.046	GT104.2337.025.22.40.R	4.00	0.25	23	8	1.70	3.70	0.30	22.00	40.00	4.00
4.047	GT104.2337.025.27.40.R	4.00	0.25	23	8	1.70	3.70	0.30	27.00	45.00	4.00
4.048	GT104.2337.025.32.40.R	4.00	0.25	23	8	1.70	3.70	0.30	32.00	50.00	4.00

		Article no.		25051	25053	25055	25057				
		Cutting direction		(L)	(L)	(L)	(L)				
Code no.	Description	D min	R	W1	W2	f	a	t max	La	Lg	D h6
		mm	mm	°	°	mm	mm	mm	mm	mm	mm
4.001	GT104.2306.005.03.07.L	0.70	0.05	23	8	1.95	0.60	0.05	3.00	25.00	4.00
4.002	GT104.2309.005.04.10.L	1.00	0.05	23	8	1.95	0.90	0.10	4.00	25.00	4.00
4.003	GT104.2309.005.07.10.L	1.00	0.05	23	8	1.95	0.90	0.10	7.00	25.00	4.00
4.004	GT104.2314.005.04.15.L	1.50	0.05	23	8	1.95	1.40	0.15	4.00	25.00	4.00
4.005	GT104.2314.005.07.15.L	1.50	0.05	23	8	1.95	1.40	0.15	7.00	25.00	4.00
4.006	GT104.2314.005.12.15.L	1.50	0.05	23	8	1.95	1.40	0.15	12.00	30.00	4.00
4.007	GT104.2314.010.04.15.L	1.50	0.10	23	8	1.95	1.40	0.15	4.00	25.00	4.00
4.008	GT104.2314.010.07.15.L	1.50	0.10	23	8	1.95	1.40	0.15	7.00	25.00	4.00
4.009	GT104.2314.010.12.15.L	1.50	0.10	23	8	1.95	1.40	0.15	12.00	30.00	4.00
4.010	GT104.2319.005.04.20.L	2.00	0.05	23	8	1.95	1.90	0.15	4.00	25.00	4.00
4.011	GT104.2319.005.07.20.L	2.00	0.05	23	8	1.95	1.90	0.15	7.00	25.00	4.00
4.012	GT104.2319.005.12.20.L	2.00	0.05	23	8	1.95	1.90	0.15	12.00	30.00	4.00
4.013	GT104.2319.005.17.20.L	2.00	0.05	23	8	1.95	1.90	0.15	17.00	35.00	4.00
4.014	GT104.2319.010.04.20.L	2.00	0.10	23	8	1.95	1.90	0.15	4.00	25.00	4.00
4.015	GT104.2319.010.07.20.L	2.00	0.10	23	8	1.95	1.90	0.15	7.00	25.00	4.00
4.016	GT104.2319.010.12.20.L	2.00	0.10	23	8	1.95	1.90	0.15	12.00	30.00	4.00
4.017	GT104.2319.010.17.20.L	2.00	0.10	23	8	1.95	1.90	0.15	17.00	35.00	4.00
4.018	GT104.2319.015.04.20.L	2.00	0.15	23	8	1.95	1.90	0.15	4.00	25.00	4.00
4.019	GT104.2319.015.07.20.L	2.00	0.15	23	8	1.95	1.90	0.15	7.00	25.00	4.00
4.020	GT104.2319.015.12.20.L	2.00	0.15	23	8	1.95	1.90	0.15	12.00	30.00	4.00
4.021	GT104.2319.015.17.20.L	2.00	0.15	23	8	1.95	1.90	0.15	17.00	35.00	4.00
4.022	GT104.2326.005.07.30.L	3.00	0.05	23	8	1.95	2.60	0.20	7.00	25.00	4.00
4.023	GT104.2326.005.12.30.L	3.00	0.05	23	8	1.95	2.60	0.20	12.00	30.00	4.00
4.024	GT104.2326.005.17.30.L	3.00	0.05	23	8	1.95	2.60	0.20	17.00	35.00	4.00
4.025	GT104.2326.005.22.30.L	3.00	0.05	23	8	1.95	2.60	0.20	22.00	40.00	4.00
4.026	GT104.2326.010.07.30.L	3.00	0.10	23	8	1.95	2.60	0.20	7.00	25.00	4.00
4.027	GT104.2326.010.12.30.L	3.00	0.10	23	8	1.95	2.60	0.20	12.00	30.00	4.00
4.028	GT104.2326.010.17.30.L	3.00	0.10	23	8	1.95	2.60	0.20	17.00	35.00	4.00
4.029	GT104.2326.010.22.30.L	3.00	0.10	23	8	1.95	2.60	0.20	22.00	40.00	4.00
4.030	GT104.2326.020.07.30.L	3.00	0.20	23	8	1.95	2.60	0.20	7.00	25.00	4.00
4.031	GT104.2326.020.12.30.L	3.00	0.20	23	8	1.95	2.60	0.20	12.00	30.00	4.00
4.032	GT104.2326.020.17.30.L	3.00	0.20	23	8	1.95	2.60	0.20	17.00	35.00	4.00
4.033	GT104.2326.020.22.30.L	3.00	0.20	23	8	1.95	2.60	0.20	22.00	40.00	4.00
4.034	GT104.2337.005.12.40.L	4.00	0.05	23	8	1.70	3.70	0.30	12.00	30.00	4.00
4.035	GT104.2337.005.17.40.L	4.00	0.05	23	8	1.70	3.70	0.30	17.00	35.00	4.00
4.036	GT104.2337.005.22.40.L	4.00	0.05	23	8	1.70	3.70	0.30	22.00	40.00	4.00
4.037	GT104.2337.005.27.40.L	4.00	0.05	23	8	1.70	3.70	0.30	27.00	45.00	4.00
4.038	GT104.2337.005.32.40.L	4.00	0.05	23	8	1.70	3.70	0.30	32.00	50.00	4.00
4.039	GT104.2337.015.12.40.L	4.00	0.15	23	8	1.70	3.70	0.30	12.00	30.00	4.00
4.040	GT104.2337.015.17.40.L	4.00	0.15	23	8	1.70	3.70	0.30	17.00	35.00	4.00
4.041	GT104.2337.015.22.40.L	4.00	0.15	23	8	1.70	3.70	0.30	22.00	40.00	4.00
4.042	GT104.2337.015.27.40.L	4.00	0.15	23	8	1.70	3.70	0.30	27.00	45.00	4.00
4.043	GT104.2337.015.32.40.L	4.00	0.15	23	8	1.70	3.70	0.30	32.00	50.00	4.00
4.044	GT104.2337.025.12.40.L	4.00	0.25	23	8	1.70	3.70	0.30	12.00	30.00	4.00
4.045	GT104.2337.025.17.40.L	4.00	0.25	23	8	1.70	3.70	0.30	17.00	35.00	4.00
4.046	GT104.2337.025.22.40.L	4.00	0.25	23	8	1.70	3.70	0.30	22.00	40.00	4.00
4.047	GT104.2337.025.27.40.L	4.00	0.25	23	8	1.70	3.70	0.30	27.00	45.00	4.00
4.048	GT104.2337.025.32.40.L	4.00	0.25	23	8	1.70	3.70	0.30	32.00	50.00	4.00

Cutting insert for boring out and profiling

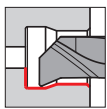

• from hole-Ø 0.7, face flat 90°

for tool holders type GH104/GB104 see from page 16

Tool material	Solid carbide			
Type	GT 104	GT 104	GT 104	GT 104
Surface	S	a	C	○
	TiN	TiAlN-nanoA	TiCN	bright

GUHRING NAVIGATOR

Cutting data page 94

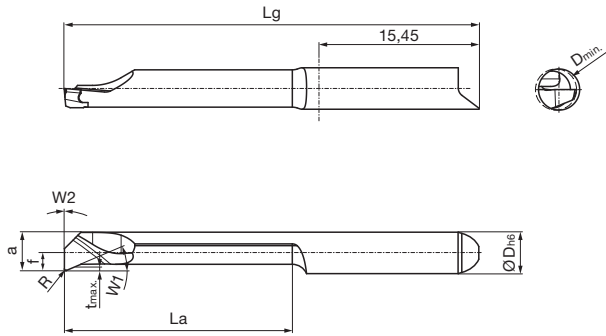

Right hand version shown
Left hand version mirror image



Article no.	25058	25060	25062	25064
Cutting direction	(R)	(R)	(R)	(R)

Code no.	Description	D min	R	W1	W2	f	a	t max	La	Lg	D h6
		mm	mm	°	°	mm	mm	mm	mm	mm	mm
4.001	GT104.9006.005.03.07.R	0.70	0.05	23	0	1.95	0.60	0.05	3.00	25.00	4.00
4.002	GT104.9009.005.04.10.R	1.00	0.05	23	0	1.95	0.90	0.10	4.00	25.00	4.00
4.003	GT104.9009.005.07.10.R	1.00	0.05	23	0	1.95	0.90	0.10	7.00	25.00	4.00
4.004	GT104.9014.005.04.15.R	1.50	0.05	23	0	1.95	1.40	0.15	4.00	25.00	4.00
4.005	GT104.9014.005.07.15.R	1.50	0.05	23	0	1.95	1.40	0.15	7.00	25.00	4.00
4.006	GT104.9014.005.12.15.R	1.50	0.05	23	0	1.95	1.40	0.15	12.00	30.00	4.00
4.007	GT104.9014.010.04.15.R	1.50	0.10	23	0	1.95	1.40	0.15	4.00	25.00	4.00
4.008	GT104.9014.010.07.15.R	1.50	0.10	23	0	1.95	1.40	0.15	7.00	25.00	4.00
4.009	GT104.9014.010.12.15.R	1.50	0.10	23	0	1.95	1.40	0.15	12.00	30.00	4.00
4.010	GT104.9019.005.04.20.R	2.00	0.05	23	0	1.95	1.90	0.15	4.00	25.00	4.00
4.011	GT104.9019.005.07.20.R	2.00	0.05	23	0	1.95	1.90	0.15	7.00	25.00	4.00
4.012	GT104.9019.005.12.20.R	2.00	0.05	23	0	1.95	1.90	0.15	12.00	30.00	4.00
4.013	GT104.9019.005.17.20.R	2.00	0.05	23	0	1.95	1.90	0.15	17.00	35.00	4.00
4.014	GT104.9019.010.04.20.R	2.00	0.10	23	0	1.95	1.90	0.15	4.00	25.00	4.00
4.015	GT104.9019.010.07.20.R	2.00	0.10	23	0	1.95	1.90	0.15	7.00	25.00	4.00
4.016	GT104.9019.010.12.20.R	2.00	0.10	23	0	1.95	1.90	0.15	12.00	30.00	4.00
4.017	GT104.9019.010.17.20.R	2.00	0.10	23	0	1.95	1.90	0.15	17.00	35.00	4.00
4.018	GT104.9019.015.04.20.R	2.00	0.15	23	0	1.95	1.90	0.15	4.00	25.00	4.00
4.019	GT104.9019.015.07.20.R	2.00	0.15	23	0	1.95	1.90	0.15	7.00	25.00	4.00
4.020	GT104.9019.015.12.20.R	2.00	0.15	23	0	1.95	1.90	0.15	12.00	30.00	4.00
4.021	GT104.9019.015.17.20.R	2.00	0.15	23	0	1.95	1.90	0.15	17.00	35.00	4.00
4.022	GT104.9026.005.07.30.R	3.00	0.05	23	0	1.95	2.60	0.20	7.00	25.00	4.00
4.023	GT104.9026.005.12.30.R	3.00	0.05	23	0	1.95	2.60	0.20	12.00	30.00	4.00
4.024	GT104.9026.005.17.30.R	3.00	0.05	23	0	1.95	2.60	0.20	17.00	35.00	4.00
4.025	GT104.9026.005.22.30.R	3.00	0.05	23	0	1.95	2.60	0.20	22.00	40.00	4.00
4.026	GT104.9026.010.07.30.R	3.00	0.10	23	0	1.95	2.60	0.20	7.00	25.00	4.00
4.027	GT104.9026.010.12.30.R	3.00	0.10	23	0	1.95	2.60	0.20	12.00	30.00	4.00
4.028	GT104.9026.010.17.30.R	3.00	0.10	23	0	1.95	2.60	0.20	17.00	35.00	4.00
4.029	GT104.9026.010.22.30.R	3.00	0.10	23	0	1.95	2.60	0.20	22.00	40.00	4.00
4.030	GT104.9026.020.07.30.R	3.00	0.20	23	0	1.95	2.60	0.20	7.00	25.00	4.00
4.031	GT104.9026.020.12.30.R	3.00	0.20	23	0	1.95	2.60	0.20	12.00	30.00	4.00
4.032	GT104.9026.020.17.30.R	3.00	0.20	23	0	1.95	2.60	0.20	17.00	35.00	4.00
4.033	GT104.9026.020.22.30.R	3.00	0.20	23	0	1.95	2.60	0.20	22.00	40.00	4.00
4.034	GT104.9037.005.12.40.R	4.00	0.05	23	0	1.70	3.70	0.30	12.00	30.00	4.00
4.035	GT104.9037.005.17.40.R	4.00	0.05	23	0	1.70	3.70	0.30	17.00	35.00	4.00
4.036	GT104.9037.005.22.40.R	4.00	0.05	23	0	1.70	3.70	0.30	22.00	40.00	4.00
4.037	GT104.9037.005.27.40.R	4.00	0.05	23	0	1.70	3.70	0.30	27.00	45.00	4.00
4.038	GT104.9037.005.32.40.R	4.00	0.05	23	0	1.70	3.70	0.30	32.00	50.00	4.00
4.039	GT104.9037.015.12.40.R	4.00	0.15	23	0	1.70	3.70	0.30	12.00	30.00	4.00
4.040	GT104.9037.015.17.40.R	4.00	0.15	23	0	1.70	3.70	0.30	17.00	35.00	4.00
4.041	GT104.9037.015.22.40.R	4.00	0.15	23	0	1.70	3.70	0.30	22.00	40.00	4.00
4.042	GT104.9037.015.27.40.R	4.00	0.15	23	0	1.70	3.70	0.30	27.00	45.00	4.00



												Article no.	25058	25060	25062	25064			
												Cutting direction				(R)	(R)	(R)	(R)
Code no.	Description	D min	R	W1	W2	f	a	t max	La	Lg	D h6								
		mm	mm	°	°	mm	mm	mm	mm	mm	mm								
4.043	GT104.9037.015.32.40.R	4.00	0.15	23	0	1.70	3.70	0.30	32.00	50.00	4.00								
4.044	GT104.9037.025.12.40.R	4.00	0.25	23	0	1.70	3.70	0.30	12.00	30.00	4.00								
4.045	GT104.9037.025.17.40.R	4.00	0.25	23	0	1.70	3.70	0.30	17.00	35.00	4.00								
4.046	GT104.9037.025.22.40.R	4.00	0.25	23	0	1.70	3.70	0.30	22.00	40.00	4.00								
4.047	GT104.9037.025.27.40.R	4.00	0.25	23	0	1.70	3.70	0.30	27.00	45.00	4.00								
4.048	GT104.9037.025.32.40.R	4.00	0.25	23	0	1.70	3.70	0.30	32.00	50.00	4.00								

												Article no.	25059	25061	25063	25065			
												Cutting direction				(L)	(L)	(L)	(L)
Code no.	Description	D min	R	W1	W2	f	a	t max	La	Lg	D h6								
		mm	mm	°	°	mm	mm	mm	mm	mm	mm								
4.001	GT104.9006.005.03.07.L	0.70	0.05	23	0	1.95	0.60	0.05	3.00	25.00	4.00								
4.002	GT104.9009.005.04.10.L	1.00	0.05	23	0	1.95	0.90	0.10	4.00	25.00	4.00								
4.003	GT104.9009.005.07.10.L	1.00	0.05	23	0	1.95	0.90	0.10	7.00	25.00	4.00								
4.004	GT104.9014.005.04.15.L	1.50	0.05	23	0	1.95	1.40	0.15	4.00	25.00	4.00								
4.005	GT104.9014.005.07.15.L	1.50	0.05	23	0	1.95	1.40	0.15	7.00	25.00	4.00								
4.006	GT104.9014.005.12.15.L	1.50	0.05	23	0	1.95	1.40	0.15	12.00	30.00	4.00								
4.007	GT104.9014.010.04.15.L	1.50	0.10	23	0	1.95	1.40	0.15	4.00	25.00	4.00								
4.008	GT104.9014.010.07.15.L	1.50	0.10	23	0	1.95	1.40	0.15	7.00	25.00	4.00								
4.009	GT104.9014.010.12.15.L	1.50	0.10	23	0	1.95	1.40	0.15	12.00	30.00	4.00								
4.010	GT104.9019.005.04.20.L	2.00	0.05	23	0	1.95	1.90	0.15	4.00	25.00	4.00								
4.011	GT104.9019.005.07.20.L	2.00	0.05	23	0	1.95	1.90	0.15	7.00	25.00	4.00								
4.012	GT104.9019.005.12.20.L	2.00	0.05	23	0	1.95	1.90	0.15	12.00	30.00	4.00								
4.013	GT104.9019.005.17.20.L	2.00	0.05	23	0	1.95	1.90	0.15	17.00	35.00	4.00								
4.014	GT104.9019.010.04.20.L	2.00	0.10	23	0	1.95	1.90	0.15	4.00	25.00	4.00								
4.015	GT104.9019.010.07.20.L	2.00	0.10	23	0	1.95	1.90	0.15	7.00	25.00	4.00								
4.016	GT104.9019.010.12.20.L	2.00	0.10	23	0	1.95	1.90	0.15	12.00	30.00	4.00								
4.017	GT104.9019.010.17.20.L	2.00	0.10	23	0	1.95	1.90	0.15	17.00	35.00	4.00								
4.018	GT104.9019.015.04.20.L	2.00	0.15	23	0	1.95	1.90	0.15	4.00	25.00	4.00								
4.019	GT104.9019.015.07.20.L	2.00	0.15	23	0	1.95	1.90	0.15	7.00	25.00	4.00								
4.020	GT104.9019.015.12.20.L	2.00	0.15	23	0	1.95	1.90	0.15	12.00	30.00	4.00								
4.021	GT104.9019.015.17.20.L	2.00	0.15	23	0	1.95	1.90	0.15	17.00	35.00	4.00								
4.022	GT104.9026.005.07.30.L	3.00	0.05	23	0	1.95	2.60	0.20	7.00	25.00	4.00								
4.023	GT104.9026.005.12.30.L	3.00	0.05	23	0	1.95	2.60	0.20	12.00	30.00	4.00								
4.024	GT104.9026.005.17.30.L	3.00	0.05	23	0	1.95	2.60	0.20	17.00	35.00	4.00								
4.025	GT104.9026.005.22.30.L	3.00	0.05	23	0	1.95	2.60	0.20	22.00	40.00	4.00								
4.026	GT104.9026.010.07.30.L	3.00	0.10	23	0	1.95	2.60	0.20	7.00	25.00	4.00								
4.027	GT104.9026.010.12.30.L	3.00	0.10	23	0	1.95	2.60	0.20	12.00	30.00	4.00								
4.028	GT104.9026.010.17.30.L	3.00	0.10	23	0	1.95	2.60	0.20	17.00	35.00	4.00								
4.029	GT104.9026.010.22.30.L	3.00	0.10	23	0	1.95	2.60	0.20	22.00	40.00	4.00								
4.030	GT104.9026.020.07.30.L	3.00	0.20	23	0	1.95	2.60	0.20	7.00	25.00	4.00								
4.031	GT104.9026.020.12.30.L	3.00	0.20	23	0	1.95	2.60	0.20	12.00	30.00	4.00								
4.032	GT104.9026.020.17.30.L	3.00	0.20	23	0	1.95	2.60	0.20	17.00	35.00	4.00								
4.033	GT104.9026.020.22.30.L	3.00	0.20	23	0	1.95	2.60	0.20	22.00	40.00	4.00								
4.034	GT104.9037.005.12.40.L	4.00	0.05	23	0	1.70	3.70	0.30	12.00	30.00	4.00								
4.035	GT104.9037.005.17.40.L	4.00	0.05	23	0	1.70	3.70	0.30	17.00	35.00	4.00								
4.036	GT104.9037.005.22.40.L	4.00	0.05	23	0	1.70	3.70	0.30	22.00	40.00	4.00								
4.037	GT104.9037.005.27.40.L	4.00	0.05	23	0	1.70	3.70	0.30	27.00	45.00	4.00								
4.038	GT104.9037.005.32.40.L	4.00	0.05	23	0	1.70	3.70	0.30	32.00	50.00	4.00								
4.039	GT104.9037.015.12.40.L	4.00	0.15	23	0	1.70	3.70	0.30	12.00	30.00	4.00								
4.040	GT104.9037.015.17.40.L	4.00	0.15	23	0	1.70	3.70	0.30	17.00	35.00	4.00								
4.041	GT104.9037.015.22.40.L	4.00	0.15	23	0	1.70	3.70	0.30	22.00	40.00	4.00								
4.042	GT104.9037.015.27.40.L	4.00	0.15	23	0	1.70	3.70	0.30	27.00	45.00	4.00								
4.043	GT104.9037.015.32.40.L	4.00	0.15	23	0	1.70	3.70	0.30	32.00	50.00	4.00								
4.044	GT104.9037.025.12.40.L	4.00	0.25	23	0	1.70	3.70	0.30	12.00	30.00	4.00								
4.045	GT104.9037.025.17.40.L	4.00	0.25	23	0	1.70	3.70	0.30	17.00	35.00	4.00								
4.046	GT104.9037.025.22.40.L	4.00	0.25	23	0	1.70	3.70	0.30	22.00	40.00	4.00								
4.047	GT104.9037.025.27.40.L	4.00	0.25	23	0	1.70	3.70	0.30	27.00	45.00	4.00								
4.048	GT104.9037.025.32.40.L	4.00	0.25	23	0	1.70	3.70	0.30	32.00	50.00	4.00								

Cutting insert for boring out and profiling

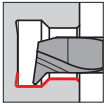

• from hole-Ø 2, radial free 47°

for tool holders type GH104/GB104 see from page 16

Tool material	Solid carbide			
	GT 104	GT 104	GT 104	GT 104
Type	GT 104	GT 104	GT 104	GT 104
Surface	S	a	C	○
	TiN	TiAlN-nanoA	TiCN	bright

GUHRING NAVIGATOR

Cutting data page 94

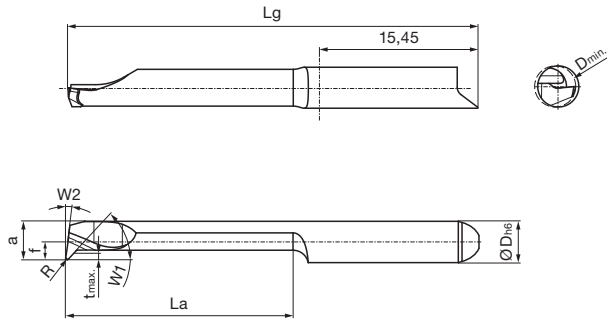

Right hand version shown
Left hand version mirror image



Article no.	25066	25068	25070	25072
Cutting direction	(R)	(R)	(R)	(R)

Code no.	Description	D min	R	W1	W2	f	a	t max	La	Lg	D h6
		mm	mm	°	°	mm	mm	mm	mm	mm	mm
4.001	GT104.4717.005.04.20.R	2.00	0.05	47	8	1.95	1.70	0.35	4.00	25.00	4.00
4.002	GT104.4717.005.07.20.R	2.00	0.05	47	8	1.95	1.70	0.35	7.00	25.00	4.00
4.003	GT104.4717.005.12.20.R	2.00	0.05	47	8	1.95	1.70	0.35	12.00	30.00	4.00
4.004	GT104.4717.005.17.20.R	2.00	0.05	47	8	1.95	1.70	0.35	17.00	35.00	4.00
4.005	GT104.4717.010.04.20.R	2.00	0.10	47	8	1.95	1.70	0.35	4.00	25.00	4.00
4.006	GT104.4717.010.07.20.R	2.00	0.10	47	8	1.95	1.70	0.35	7.00	25.00	4.00
4.007	GT104.4717.010.12.20.R	2.00	0.10	47	8	1.95	1.70	0.35	12.00	30.00	4.00
4.008	GT104.4717.010.17.20.R	2.00	0.10	47	8	1.95	1.70	0.35	17.00	35.00	4.00
4.009	GT104.4717.015.04.20.R	2.00	0.15	47	8	1.95	1.70	0.35	4.00	25.00	4.00
4.010	GT104.4717.015.07.20.R	2.00	0.15	47	8	1.95	1.70	0.35	7.00	25.00	4.00
4.011	GT104.4717.015.12.20.R	2.00	0.15	47	8	1.95	1.70	0.35	12.00	30.00	4.00
4.012	GT104.4717.015.17.20.R	2.00	0.15	47	8	1.95	1.70	0.35	17.00	35.00	4.00
4.013	GT104.4727.005.07.30.R	3.00	0.05	47	8	1.95	2.70	0.55	7.00	25.00	4.00
4.014	GT104.4727.005.12.30.R	3.00	0.05	47	8	1.95	2.70	0.55	12.00	30.00	4.00
4.015	GT104.4727.005.17.30.R	3.00	0.05	47	8	1.95	2.70	0.55	17.00	35.00	4.00
4.016	GT104.4727.005.22.30.R	3.00	0.05	47	8	1.95	2.70	0.55	22.00	40.00	4.00
4.017	GT104.4727.010.07.30.R	3.00	0.10	47	8	1.95	2.70	0.55	7.00	25.00	4.00
4.018	GT104.4727.010.12.30.R	3.00	0.10	47	8	1.95	2.70	0.55	12.00	30.00	4.00
4.019	GT104.4727.010.17.30.R	3.00	0.10	47	8	1.95	2.70	0.55	17.00	35.00	4.00
4.020	GT104.4727.010.22.30.R	3.00	0.10	47	8	1.95	2.70	0.55	22.00	40.00	4.00
4.021	GT104.4727.025.07.30.R	3.00	0.25	47	8	1.95	2.70	0.55	7.00	25.00	4.00
4.022	GT104.4727.025.12.30.R	3.00	0.25	47	8	1.95	2.70	0.55	12.00	30.00	4.00
4.023	GT104.4727.025.17.30.R	3.00	0.25	47	8	1.95	2.70	0.55	17.00	35.00	4.00
4.024	GT104.4727.025.22.30.R	3.00	0.25	47	8	1.95	2.70	0.55	22.00	40.00	4.00
4.025	GT104.4737.005.12.40.R	4.00	0.05	47	8	1.70	3.70	0.60	12.00	30.00	4.00
4.026	GT104.4737.005.17.40.R	4.00	0.05	47	8	1.70	3.70	0.60	17.00	35.00	4.00
4.027	GT104.4737.005.22.40.R	4.00	0.05	47	8	1.70	3.70	0.60	22.00	40.00	4.00
4.028	GT104.4737.005.27.40.R	4.00	0.05	47	8	1.70	3.70	0.60	27.00	45.00	4.00
4.029	GT104.4737.005.32.40.R	4.00	0.05	47	8	1.70	3.70	0.60	32.00	50.00	4.00
4.030	GT104.4737.015.12.40.R	4.00	0.15	47	8	1.70	3.70	0.60	12.00	30.00	4.00
4.031	GT104.4737.015.17.40.R	4.00	0.15	47	8	1.70	3.70	0.60	17.00	35.00	4.00
4.032	GT104.4737.015.22.40.R	4.00	0.15	47	8	1.70	3.70	0.60	22.00	40.00	4.00
4.033	GT104.4737.015.27.40.R	4.00	0.15	47	8	1.70	3.70	0.60	27.00	45.00	4.00
4.034	GT104.4737.015.32.40.R	4.00	0.15	47	8	1.70	3.70	0.60	32.00	50.00	4.00
4.035	GT104.4737.025.12.40.R	4.00	0.25	47	8	1.70	3.70	0.60	12.00	30.00	4.00
4.036	GT104.4737.025.17.40.R	4.00	0.25	47	8	1.70	3.70	0.60	17.00	35.00	4.00
4.037	GT104.4737.025.22.40.R	4.00	0.25	47	8	1.70	3.70	0.60	22.00	40.00	4.00
4.038	GT104.4737.025.27.40.R	4.00	0.25	47	8	1.70	3.70	0.60	27.00	45.00	4.00
4.039	GT104.4737.025.32.40.R	4.00	0.25	47	8	1.70	3.70	0.60	32.00	50.00	4.00

Article no. **25067** **25069** **25071** **25073**Cutting direction    

System 104

Code no.	Description	D min	R	W1	W2	f	a	t max	La	Lg	D h6
		mm	mm	°	°	mm	mm	mm	mm	mm	mm
4.001	GT104.4717.005.04.20.L	2.00	0.05	47	8	1.95	1.70	0.35	4.00	25.00	4.00
4.002	GT104.4717.005.07.20.L	2.00	0.05	47	8	1.95	1.70	0.35	7.00	25.00	4.00
4.003	GT104.4717.005.12.20.L	2.00	0.05	47	8	1.95	1.70	0.35	12.00	30.00	4.00
4.004	GT104.4717.005.17.20.L	2.00	0.05	47	8	1.95	1.70	0.35	17.00	35.00	4.00
4.005	GT104.4717.010.04.20.L	2.00	0.10	47	8	1.95	1.70	0.35	4.00	25.00	4.00
4.006	GT104.4717.010.07.20.L	2.00	0.10	47	8	1.95	1.70	0.35	7.00	25.00	4.00
4.007	GT104.4717.010.12.20.L	2.00	0.10	47	8	1.95	1.70	0.35	12.00	30.00	4.00
4.008	GT104.4717.010.17.20.L	2.00	0.10	47	8	1.95	1.70	0.35	17.00	35.00	4.00
4.009	GT104.4717.015.04.20.L	2.00	0.15	47	8	1.95	1.70	0.35	4.00	25.00	4.00
4.010	GT104.4717.015.07.20.L	2.00	0.15	47	8	1.95	1.70	0.35	7.00	25.00	4.00
4.011	GT104.4717.015.12.20.L	2.00	0.15	47	8	1.95	1.70	0.35	12.00	30.00	4.00
4.012	GT104.4717.015.17.20.L	2.00	0.15	47	8	1.95	1.70	0.35	17.00	35.00	4.00
4.013	GT104.4727.005.07.30.L	3.00	0.05	47	8	1.95	2.70	0.55	7.00	25.00	4.00
4.014	GT104.4727.005.12.30.L	3.00	0.05	47	8	1.95	2.70	0.55	12.00	30.00	4.00
4.015	GT104.4727.005.17.30.L	3.00	0.05	47	8	1.95	2.70	0.55	17.00	35.00	4.00
4.016	GT104.4727.005.22.30.L	3.00	0.05	47	8	1.95	2.70	0.55	22.00	40.00	4.00
4.017	GT104.4727.010.07.30.L	3.00	0.10	47	8	1.95	2.70	0.55	7.00	25.00	4.00
4.018	GT104.4727.010.12.30.L	3.00	0.10	47	8	1.95	2.70	0.55	12.00	30.00	4.00
4.019	GT104.4727.010.17.30.L	3.00	0.10	47	8	1.95	2.70	0.55	17.00	35.00	4.00
4.020	GT104.4727.010.22.30.L	3.00	0.10	47	8	1.95	2.70	0.55	22.00	40.00	4.00
4.021	GT104.4727.025.07.30.L	3.00	0.25	47	8	1.95	2.70	0.55	7.00	25.00	4.00
4.022	GT104.4727.025.12.30.L	3.00	0.25	47	8	1.95	2.70	0.55	12.00	30.00	4.00
4.023	GT104.4727.025.17.30.L	3.00	0.25	47	8	1.95	2.70	0.55	17.00	35.00	4.00
4.024	GT104.4727.025.22.30.L	3.00	0.25	47	8	1.95	2.70	0.55	22.00	40.00	4.00
4.025	GT104.4737.005.12.40.L	4.00	0.05	47	8	1.70	3.70	0.60	12.00	30.00	4.00
4.026	GT104.4737.005.17.40.L	4.00	0.05	47	8	1.70	3.70	0.60	17.00	35.00	4.00
4.027	GT104.4737.005.22.40.L	4.00	0.05	47	8	1.70	3.70	0.60	22.00	40.00	4.00
4.028	GT104.4737.005.27.40.L	4.00	0.05	47	8	1.70	3.70	0.60	27.00	45.00	4.00
4.029	GT104.4737.005.32.40.L	4.00	0.05	47	8	1.70	3.70	0.60	32.00	50.00	4.00
4.030	GT104.4737.015.12.40.L	4.00	0.15	47	8	1.70	3.70	0.60	12.00	30.00	4.00
4.031	GT104.4737.015.17.40.L	4.00	0.15	47	8	1.70	3.70	0.60	17.00	35.00	4.00
4.032	GT104.4737.015.22.40.L	4.00	0.15	47	8	1.70	3.70	0.60	22.00	40.00	4.00
4.033	GT104.4737.015.27.40.L	4.00	0.15	47	8	1.70	3.70	0.60	27.00	45.00	4.00
4.034	GT104.4737.015.32.40.L	4.00	0.15	47	8	1.70	3.70	0.60	32.00	50.00	4.00
4.035	GT104.4737.025.12.40.L	4.00	0.25	47	8	1.70	3.70	0.60	12.00	30.00	4.00
4.036	GT104.4737.025.17.40.L	4.00	0.25	47	8	1.70	3.70	0.60	17.00	35.00	4.00
4.037	GT104.4737.025.22.40.L	4.00	0.25	47	8	1.70	3.70	0.60	22.00	40.00	4.00
4.038	GT104.4737.025.27.40.L	4.00	0.25	47	8	1.70	3.70	0.60	27.00	45.00	4.00
4.039	GT104.4737.025.32.40.L	4.00	0.25	47	8	1.70	3.70	0.60	32.00	50.00	4.00

Cutting insert for boring out and profiling

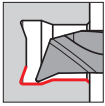

• from hole-Ø 3, face free 20°

for tool holders type GH104/GB104 see from page 16

Tool material	Solid carbide			
Type	GT 104	GT 104	GT 104	GT 104
Surface	S	a	C	○
	TiN	TiAlN-nanoA	TiCN	bright

GUHRING NAVIGATOR

Cutting data page 94

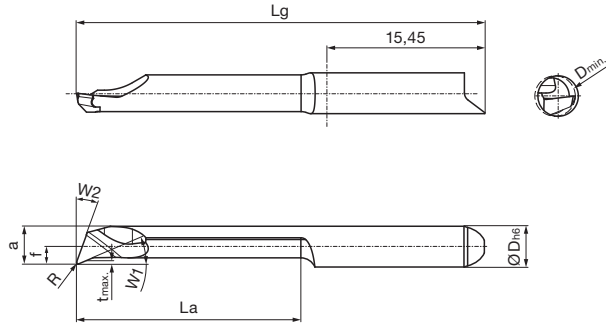

Right hand version shown
Left hand version mirror image



Article no.	25074	25076	25078	25080
Cutting direction	(R)	(R)	(R)	(R)

Code no.	Description	D min	R	W1	W2	f	a	t max	La	Lg	D h6
		mm	mm	°	°	mm	mm	mm	mm	mm	mm
4.001	GT104.2026.005.07.30.R	3.00	0.05	23	20	1.95	2.60	0.20	7.00	25.00	4.00
4.002	GT104.2026.005.12.30.R	3.00	0.05	23	20	1.95	2.60	0.20	12.00	30.00	4.00
4.003	GT104.2026.005.17.30.R	3.00	0.05	23	20	1.95	2.60	0.20	17.00	35.00	4.00
4.004	GT104.2026.005.22.30.R	3.00	0.05	23	20	1.95	2.60	0.20	22.00	40.00	4.00
4.005	GT104.2026.010.07.30.R	3.00	0.10	23	20	1.95	2.60	0.20	7.00	25.00	4.00
4.006	GT104.2026.010.12.30.R	3.00	0.10	23	20	1.95	2.60	0.20	12.00	30.00	4.00
4.007	GT104.2026.010.17.30.R	3.00	0.10	23	20	1.95	2.60	0.20	17.00	35.00	4.00
4.008	GT104.2026.010.22.30.R	3.00	0.10	23	20	1.95	2.60	0.20	22.00	40.00	4.00
4.009	GT104.2026.020.07.30.R	3.00	0.20	23	20	1.95	2.60	0.20	7.00	25.00	4.00
4.010	GT104.2026.020.12.30.R	3.00	0.20	23	20	1.95	2.60	0.20	12.00	30.00	4.00
4.011	GT104.2026.020.17.30.R	3.00	0.20	23	20	1.95	2.60	0.20	17.00	35.00	4.00
4.012	GT104.2026.020.22.30.R	3.00	0.20	23	20	1.95	2.60	0.20	22.00	40.00	4.00
4.013	GT104.2037.005.12.40.R	4.00	0.05	23	20	1.70	3.70	0.30	12.00	30.00	4.00
4.014	GT104.2037.005.17.40.R	4.00	0.05	23	20	1.70	3.70	0.30	17.00	35.00	4.00
4.015	GT104.2037.005.22.40.R	4.00	0.05	23	20	1.70	3.70	0.30	22.00	40.00	4.00
4.016	GT104.2037.005.27.40.R	4.00	0.05	23	20	1.70	3.70	0.30	27.00	45.00	4.00
4.017	GT104.2037.005.32.40.R	4.00	0.05	23	20	1.70	3.70	0.30	32.00	50.00	4.00
4.018	GT104.2037.015.12.40.R	4.00	0.15	23	20	1.70	3.70	0.30	12.00	30.00	4.00
4.019	GT104.2037.015.17.40.R	4.00	0.15	23	20	1.70	3.70	0.30	17.00	35.00	4.00
4.020	GT104.2037.015.22.40.R	4.00	0.15	23	20	1.70	3.70	0.30	22.00	40.00	4.00
4.021	GT104.2037.015.27.40.R	4.00	0.15	23	20	1.70	3.70	0.30	27.00	45.00	4.00
4.022	GT104.2037.015.32.40.R	4.00	0.15	23	20	1.70	3.70	0.30	32.00	50.00	4.00
4.023	GT104.2037.025.12.40.R	4.00	0.25	23	20	1.70	3.70	0.30	12.00	30.00	4.00
4.024	GT104.2037.025.17.40.R	4.00	0.25	23	20	1.70	3.70	0.30	17.00	35.00	4.00
4.025	GT104.2037.025.22.40.R	4.00	0.25	23	20	1.70	3.70	0.30	22.00	40.00	4.00
4.026	GT104.2037.025.27.40.R	4.00	0.25	23	20	1.70	3.70	0.30	27.00	45.00	4.00
4.027	GT104.2037.025.32.40.R	4.00	0.25	23	20	1.70	3.70	0.30	32.00	50.00	4.00

Article no.	25075	25077	25079	25081
Cutting direction	(L)	(L)	(L)	(L)

Code no.	Description	D min	R	W1	W2	f	a	t max	La	Lg	D h6
		mm	mm	°	°	mm	mm	mm	mm	mm	mm
4.001	GT104.2026.005.07.30.L	3.00	0.05	23	20	1.95	2.60	0.20	7.00	25.00	4.00
4.002	GT104.2026.005.12.30.L	3.00	0.05	23	20	1.95	2.60	0.20	12.00	30.00	4.00
4.003	GT104.2026.005.17.30.L	3.00	0.05	23	20	1.95	2.60	0.20	17.00	35.00	4.00
4.004	GT104.2026.005.22.30.L	3.00	0.05	23	20	1.95	2.60	0.20	22.00	40.00	4.00
4.005	GT104.2026.010.07.30.L	3.00	0.10	23	20	1.95	2.60	0.20	7.00	25.00	4.00
4.006	GT104.2026.010.12.30.L	3.00	0.10	23	20	1.95	2.60	0.20	12.00	30.00	4.00



Article no. **25075** **25077** **25079** **25081**

Cutting direction    

System 104

Code no.	Description	D min	R	W1	W2	f	a	t max	La	Lg	D h6
		mm	mm	°	°	mm	mm	mm	mm	mm	mm
4.007	GT104.2026.010.17.30.L	3.00	0.10	23	20	1.95	2.60	0.20	17.00	35.00	4.00
4.008	GT104.2026.010.22.30.L	3.00	0.10	23	20	1.95	2.60	0.20	22.00	40.00	4.00
4.009	GT104.2026.020.07.30.L	3.00	0.20	23	20	1.95	2.60	0.20	7.00	25.00	4.00
4.010	GT104.2026.020.12.30.L	3.00	0.20	23	20	1.95	2.60	0.20	12.00	30.00	4.00
4.011	GT104.2026.020.17.30.L	3.00	0.20	23	20	1.95	2.60	0.20	17.00	35.00	4.00
4.012	GT104.2026.020.22.30.L	3.00	0.20	23	20	1.95	2.60	0.20	22.00	40.00	4.00
4.013	GT104.2037.005.12.40.L	4.00	0.05	23	20	1.70	3.70	0.30	12.00	30.00	4.00
4.014	GT104.2037.005.17.40.L	4.00	0.05	23	20	1.70	3.70	0.30	17.00	35.00	4.00
4.015	GT104.2037.005.22.40.L	4.00	0.05	23	20	1.70	3.70	0.30	22.00	40.00	4.00
4.016	GT104.2037.005.27.40.L	4.00	0.05	23	20	1.70	3.70	0.30	27.00	45.00	4.00
4.017	GT104.2037.005.32.40.L	4.00	0.05	23	20	1.70	3.70	0.30	32.00	50.00	4.00
4.018	GT104.2037.015.12.40.L	4.00	0.15	23	20	1.70	3.70	0.30	12.00	30.00	4.00
4.019	GT104.2037.015.17.40.L	4.00	0.15	23	20	1.70	3.70	0.30	17.00	35.00	4.00
4.020	GT104.2037.015.22.40.L	4.00	0.15	23	20	1.70	3.70	0.30	22.00	40.00	4.00
4.021	GT104.2037.015.27.40.L	4.00	0.15	23	20	1.70	3.70	0.30	27.00	45.00	4.00
4.022	GT104.2037.015.32.40.L	4.00	0.15	23	20	1.70	3.70	0.30	32.00	50.00	4.00
4.023	GT104.2037.025.12.40.L	4.00	0.25	23	20	1.70	3.70	0.30	12.00	30.00	4.00
4.024	GT104.2037.025.17.40.L	4.00	0.25	23	20	1.70	3.70	0.30	17.00	35.00	4.00
4.025	GT104.2037.025.22.40.L	4.00	0.25	23	20	1.70	3.70	0.30	22.00	40.00	4.00
4.026	GT104.2037.025.27.40.L	4.00	0.25	23	20	1.70	3.70	0.30	27.00	45.00	4.00
4.027	GT104.2037.025.32.40.L	4.00	0.25	23	20	1.70	3.70	0.30	32.00	50.00	4.00

Cutting insert for boring out and profiling

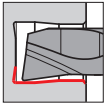

• from hole-Ø 3, radial free 8°

for tool holders type GH104/GB104 see from page 16

Tool material	Solid carbide			
	GT 104	GT 104	GT 104	GT 104
Type	GT 104	GT 104	GT 104	GT 104
Surface	S	a	C	○
	TiN	TiAlN-nanoA	TiCN	bright

GUHRING NAVIGATOR

Cutting data page 94

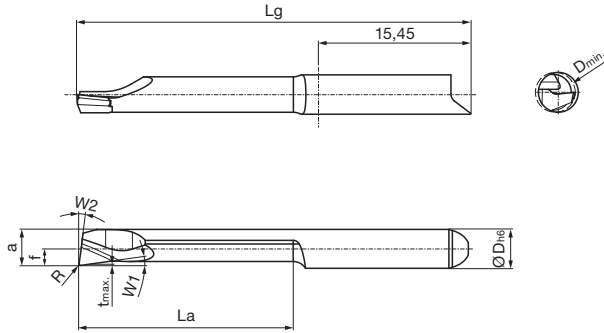

Right hand version shown
Left hand version mirror image

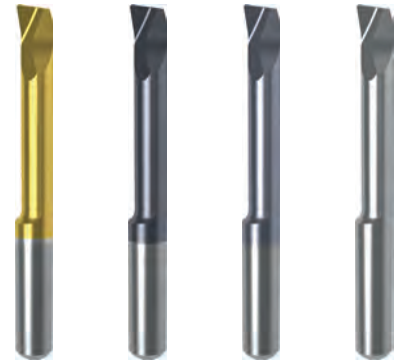

Article no.	25082	25084	25086	25088
Cutting direction	(R)	(R)	(R)	(R)

Code no.	Description	D min	R	W1	W2	f	a	t max	La	Lg	D h6
		mm	mm	°	°	mm	mm	mm	mm	mm	mm
4.001	GT104.0827.005.07.30.R	3.00	0.05	8	8	1.95	2.70	0.15	7.00	25.00	4.00
4.002	GT104.0827.005.12.30.R	3.00	0.05	8	8	1.95	2.70	0.15	12.00	30.00	4.00
4.003	GT104.0827.005.17.30.R	3.00	0.05	8	8	1.95	2.70	0.15	17.00	35.00	4.00
4.004	GT104.0827.005.22.30.R	3.00	0.05	8	8	1.95	2.70	0.15	22.00	40.00	4.00
4.005	GT104.0827.010.07.30.R	3.00	0.10	8	8	1.95	2.70	0.15	7.00	25.00	4.00
4.006	GT104.0827.010.12.30.R	3.00	0.10	8	8	1.95	2.70	0.15	12.00	30.00	4.00
4.007	GT104.0827.010.17.30.R	3.00	0.10	8	8	1.95	2.70	0.15	17.00	35.00	4.00
4.008	GT104.0827.010.22.30.R	3.00	0.10	8	8	1.95	2.70	0.15	22.00	40.00	4.00
4.009	GT104.0827.020.07.30.R	3.00	0.20	8	8	1.95	2.70	0.15	7.00	25.00	4.00
4.010	GT104.0827.020.12.30.R	3.00	0.20	8	8	1.95	2.70	0.15	12.00	30.00	4.00
4.011	GT104.0827.020.17.30.R	3.00	0.20	8	8	1.95	2.70	0.15	17.00	35.00	4.00
4.012	GT104.0827.020.22.30.R	3.00	0.20	8	8	1.95	2.70	0.15	22.00	40.00	4.00
4.013	GT104.0837.005.12.40.R	4.00	0.05	8	8	1.70	3.70	0.15	12.00	30.00	4.00
4.014	GT104.0837.005.17.40.R	4.00	0.05	8	8	1.70	3.70	0.15	17.00	35.00	4.00
4.015	GT104.0837.005.22.40.R	4.00	0.05	8	8	1.70	3.70	0.15	22.00	40.00	4.00
4.016	GT104.0837.005.27.40.R	4.00	0.05	8	8	1.70	3.70	0.15	27.00	45.00	4.00
4.017	GT104.0837.005.32.40.R	4.00	0.05	8	8	1.70	3.70	0.15	32.00	50.00	4.00
4.018	GT104.0837.015.12.40.R	4.00	0.15	8	8	1.70	3.70	0.15	12.00	30.00	4.00
4.019	GT104.0837.015.17.40.R	4.00	0.15	8	8	1.70	3.70	0.15	17.00	35.00	4.00
4.020	GT104.0837.015.22.40.R	4.00	0.15	8	8	1.70	3.70	0.15	22.00	40.00	4.00
4.021	GT104.0837.015.27.40.R	4.00	0.15	8	8	1.70	3.70	0.15	27.00	45.00	4.00
4.022	GT104.0837.015.32.40.R	4.00	0.15	8	8	1.70	3.70	0.15	32.00	50.00	4.00
4.023	GT104.0837.025.12.40.R	4.00	0.25	8	8	1.70	3.70	0.15	12.00	30.00	4.00
4.024	GT104.0837.025.17.40.R	4.00	0.25	8	8	1.70	3.70	0.15	17.00	35.00	4.00
4.025	GT104.0837.025.22.40.R	4.00	0.25	8	8	1.70	3.70	0.15	22.00	40.00	4.00
4.026	GT104.0837.025.27.40.R	4.00	0.25	8	8	1.70	3.70	0.15	27.00	45.00	4.00
4.027	GT104.0837.025.32.40.R	4.00	0.25	8	8	1.70	3.70	0.15	32.00	50.00	4.00

Article no.	25083	25085	25087	25089
Cutting direction	(L)	(L)	(L)	(L)

Code no.	Description	D min	R	W1	W2	f	a	t max	La	Lg	D h6
		mm	mm	°	°	mm	mm	mm	mm	mm	mm
4.001	GT104.0827.005.07.30.L	3.00	0.05	8	8	1.95	2.70	0.15	7.00	25.00	4.00
4.002	GT104.0827.005.12.30.L	3.00	0.05	8	8	1.95	2.70	0.15	12.00	30.00	4.00
4.003	GT104.0827.005.17.30.L	3.00	0.05	8	8	1.95	2.70	0.15	17.00	35.00	4.00
4.004	GT104.0827.005.22.30.L	3.00	0.05	8	8	1.95	2.70	0.15	22.00	40.00	4.00
4.005	GT104.0827.010.07.30.L	3.00	0.10	8	8	1.95	2.70	0.15	7.00	25.00	4.00
4.006	GT104.0827.010.12.30.L	3.00	0.10	8	8	1.95	2.70	0.15	12.00	30.00	4.00

Article no. **25083** **25085** **25087** **25089**Cutting direction    

System 104

Code no.	Description	D min	R	W1	W2	f	a	t max	La	Lg	D h6
		mm	mm	°	°	mm	mm	mm	mm	mm	mm
4.007	GT104.0827.010.17.30.L	3.00	0.10	8	8	1.95	2.70	0.15	17.00	35.00	4.00
4.008	GT104.0827.010.22.30.L	3.00	0.10	8	8	1.95	2.70	0.15	22.00	40.00	4.00
4.009	GT104.0827.020.07.30.L	3.00	0.20	8	8	1.95	2.70	0.15	7.00	25.00	4.00
4.010	GT104.0827.020.12.30.L	3.00	0.20	8	8	1.95	2.70	0.15	12.00	30.00	4.00
4.011	GT104.0827.020.17.30.L	3.00	0.20	8	8	1.95	2.70	0.15	17.00	35.00	4.00
4.012	GT104.0827.020.22.30.L	3.00	0.20	8	8	1.95	2.70	0.15	22.00	40.00	4.00
4.013	GT104.0837.005.12.40.L	4.00	0.05	8	8	1.70	3.70	0.15	12.00	30.00	4.00
4.014	GT104.0837.005.17.40.L	4.00	0.05	8	8	1.70	3.70	0.15	17.00	35.00	4.00
4.015	GT104.0837.005.22.40.L	4.00	0.05	8	8	1.70	3.70	0.15	22.00	40.00	4.00
4.016	GT104.0837.005.27.40.L	4.00	0.05	8	8	1.70	3.70	0.15	27.00	45.00	4.00
4.017	GT104.0837.005.32.40.L	4.00	0.05	8	8	1.70	3.70	0.15	32.00	50.00	4.00
4.018	GT104.0837.015.12.40.L	4.00	0.15	8	8	1.70	3.70	0.15	12.00	30.00	4.00
4.019	GT104.0837.015.17.40.L	4.00	0.15	8	8	1.70	3.70	0.15	17.00	35.00	4.00
4.020	GT104.0837.015.22.40.L	4.00	0.15	8	8	1.70	3.70	0.15	22.00	40.00	4.00
4.021	GT104.0837.015.27.40.L	4.00	0.15	8	8	1.70	3.70	0.15	27.00	45.00	4.00
4.022	GT104.0837.015.32.40.L	4.00	0.15	8	8	1.70	3.70	0.15	32.00	50.00	4.00
4.023	GT104.0837.025.12.40.L	4.00	0.25	8	8	1.70	3.70	0.15	12.00	30.00	4.00
4.024	GT104.0837.025.17.40.L	4.00	0.25	8	8	1.70	3.70	0.15	17.00	35.00	4.00
4.025	GT104.0837.025.22.40.L	4.00	0.25	8	8	1.70	3.70	0.15	22.00	40.00	4.00
4.026	GT104.0837.025.27.40.L	4.00	0.25	8	8	1.70	3.70	0.15	27.00	45.00	4.00
4.027	GT104.0837.025.32.40.L	4.00	0.25	8	8	1.70	3.70	0.15	32.00	50.00	4.00

Cutting insert for boring out and profiling

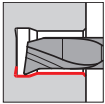

• from hole-Ø 2, VIPER-geometry

for tool holders type GH104/GB104 see from page 16

Tool material	Solid carbide			
	GJ 104	GJ 104	GJ 104	GJ 104
Type				
Surface	S	a	C	
	TiN	TiAlN-nanoA	TiCN	bright

GUHRING NAVIGATOR

Cutting data page 94

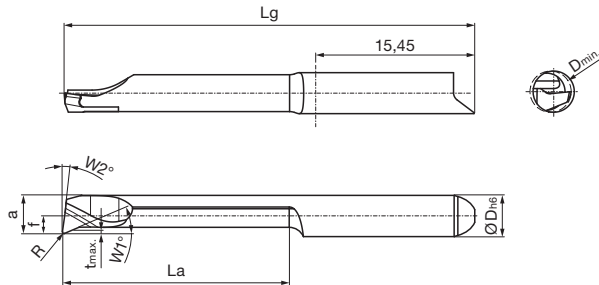

Right hand version shown
Left hand version mirror image



Article no.	25090	25092	25094	25096
Cutting direction	(R)	(R)	(R)	(R)

Code no.	Description	D min	R	W1	W2	f	a	t max	La	Lg	D h6
		mm	mm	°	°	mm	mm	mm	mm	mm	mm
4.001	GJ104.2319.010.04.20.R	2.00	0.10	23	8	1.95	1.90	0.15	4.00	25.00	4.00
4.002	GJ104.2319.010.07.20.R	2.00	0.10	23	8	1.95	1.90	0.15	7.00	25.00	4.00
4.003	GJ104.2319.010.12.20.R	2.00	0.10	23	8	1.95	1.90	0.15	12.00	30.00	4.00
4.004	GJ104.2319.010.17.20.R	2.00	0.10	23	8	1.95	1.90	0.15	17.00	35.00	4.00
4.005	GJ104.2326.015.07.30.R	3.00	0.15	23	8	1.95	2.60	0.20	7.00	25.00	4.00
4.006	GJ104.2326.015.12.30.R	3.00	0.15	23	8	1.95	2.60	0.20	12.00	30.00	4.00
4.007	GJ104.2326.015.17.30.R	3.00	0.15	23	8	1.95	2.60	0.20	17.00	35.00	4.00
4.008	GJ104.2326.015.22.30.R	3.00	0.15	23	8	1.95	2.60	0.20	22.00	40.00	4.00
4.009	GJ104.2337.020.12.40.R	4.00	0.20	23	8	1.70	3.70	0.30	12.00	30.00	4.00
4.010	GJ104.2337.020.17.40.R	4.00	0.20	23	8	1.70	3.70	0.30	17.00	35.00	4.00
4.011	GJ104.2337.020.22.40.R	4.00	0.20	23	8	1.70	3.70	0.30	22.00	40.00	4.00
4.012	GJ104.2337.020.27.40.R	4.00	0.20	23	8	1.70	3.70	0.30	27.00	45.00	4.00
4.013	GJ104.2337.020.32.40.R	4.00	0.20	23	8	1.70	3.70	0.30	32.00	50.00	4.00

Article no.	25091	25093	25095	25097
Cutting direction	(L)	(L)	(L)	(L)

Code no.	Description	D min	R	W1	W2	f	a	t max	La	Lg	D h6
		mm	mm	°	°	mm	mm	mm	mm	mm	mm
4.001	GJ104.2319.010.04.20.L	2.00	0.10	23	8	1.95	1.90	0.15	4.00	25.00	4.00
4.002	GJ104.2319.010.07.20.L	2.00	0.10	23	8	1.95	1.90	0.15	7.00	25.00	4.00
4.003	GJ104.2319.010.12.20.L	2.00	0.10	23	8	1.95	1.90	0.15	12.00	30.00	4.00
4.004	GJ104.2319.010.17.20.L	2.00	0.10	23	8	1.95	1.90	0.15	17.00	35.00	4.00
4.005	GJ104.2326.015.07.30.L	3.00	0.15	23	8	1.95	2.60	0.20	7.00	25.00	4.00
4.006	GJ104.2326.015.12.30.L	3.00	0.15	23	8	1.95	2.60	0.20	12.00	30.00	4.00
4.007	GJ104.2326.015.17.30.L	3.00	0.15	23	8	1.95	2.60	0.20	17.00	35.00	4.00
4.008	GJ104.2326.015.22.30.L	3.00	0.15	23	8	1.95	2.60	0.20	22.00	40.00	4.00
4.009	GJ104.2337.020.12.40.L	4.00	0.20	23	8	1.70	3.70	0.30	12.00	30.00	4.00
4.010	GJ104.2337.020.17.40.L	4.00	0.20	23	8	1.70	3.70	0.30	17.00	35.00	4.00
4.011	GJ104.2337.020.22.40.L	4.00	0.20	23	8	1.70	3.70	0.30	22.00	40.00	4.00
4.012	GJ104.2337.020.27.40.L	4.00	0.20	23	8	1.70	3.70	0.30	27.00	45.00	4.00
4.013	GJ104.2337.020.32.40.L	4.00	0.20	23	8	1.70	3.70	0.30	32.00	50.00	4.00



Cutting insert for back boring and profiling

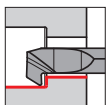

• from hole-Ø 2, radial free 32°

for tool holders type GH104/GB104 see from page 16

GUHRING NAVIGATOR

Cutting data page 94

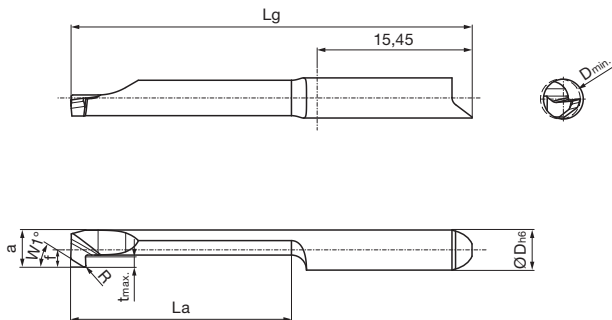

Right hand version shown
Left hand version mirror image

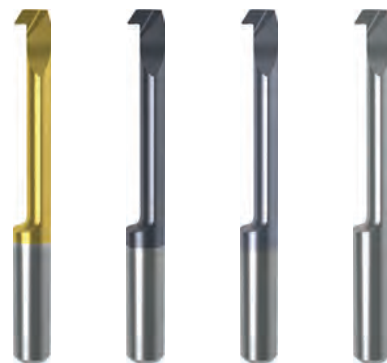

Article no.	25106	25108	25110	25112
Cutting direction				



Code no.	Description	D min	R	W1	f	a	t max	La	Lg	D h6
		mm	mm	°	mm	mm	mm	mm	mm	mm
4.001	GT104.3217.010.04.20.R	2.00	0.10	32	1.95	1.70	0.30	4.00	25.00	4.00
4.002	GT104.3217.010.07.20.R	2.00	0.10	32	1.95	1.70	0.30	7.00	25.00	4.00
4.003	GT104.3217.010.12.20.R	2.00	0.10	32	1.95	1.70	0.30	12.00	30.00	4.00
4.004	GT104.3217.010.17.20.R	2.00	0.10	32	1.95	1.70	0.70	17.00	35.00	4.00
4.005	GT104.3226.005.07.30.R	3.00	0.05	32	1.95	2.60	0.70	7.00	25.00	4.00
4.006	GT104.3226.005.12.30.R	3.00	0.05	32	1.95	2.60	0.70	12.00	30.00	4.00
4.007	GT104.3226.005.17.30.R	3.00	0.05	32	1.95	2.60	0.70	17.00	35.00	4.00
4.008	GT104.3226.005.22.30.R	3.00	0.05	32	1.95	2.60	0.70	22.00	40.00	4.00
4.009	GT104.3226.010.07.30.R	3.00	0.10	32	1.95	2.60	0.70	7.00	25.00	4.00
4.010	GT104.3226.010.12.30.R	3.00	0.10	32	1.95	2.60	0.70	12.00	30.00	4.00
4.011	GT104.3226.010.17.30.R	3.00	0.10	32	1.95	2.60	0.70	17.00	35.00	4.00
4.012	GT104.3226.010.22.30.R	3.00	0.10	32	1.95	2.60	0.70	22.00	40.00	4.00
4.013	GT104.3237.010.12.40.R	4.00	0.10	32	1.70	3.70	1.00	12.00	30.00	4.00
4.014	GT104.3237.010.17.40.R	4.00	0.10	32	1.70	3.70	1.00	17.00	35.00	4.00
4.015	GT104.3237.010.22.40.R	4.00	0.10	32	1.70	3.70	1.00	22.00	40.00	4.00
4.016	GT104.3237.010.27.40.R	4.00	0.10	32	1.70	3.70	1.00	27.00	45.00	4.00
4.017	GT104.3237.010.32.40.R	4.00	0.10	32	1.70	3.70	1.00	32.00	50.00	4.00
4.018	GT104.3237.015.12.40.R	4.00	0.15	32	1.70	3.70	1.00	12.00	30.00	4.00
4.019	GT104.3237.015.17.40.R	4.00	0.15	32	1.70	3.70	1.00	17.00	35.00	4.00
4.020	GT104.3237.015.22.40.R	4.00	0.15	32	1.70	3.70	1.00	22.00	40.00	4.00
4.021	GT104.3237.015.27.40.R	4.00	0.15	32	1.70	3.70	1.00	27.00	45.00	4.00
4.022	GT104.3237.015.32.40.R	4.00	0.15	32	1.70	3.70	1.00	32.00	50.00	4.00

Article no.	25107	25109	25111	25113
Cutting direction				

Code no.	Description	D min	R	W1	f	a	t max	La	Lg	D h6
		mm	mm	°	mm	mm	mm	mm	mm	mm
4.001	GT104.3217.010.04.20.L	2.00	0.10	32	1.95	1.70	0.30	4.00	25.00	4.00
4.002	GT104.3217.010.07.20.L	2.00	0.10	32	1.95	1.70	0.30	7.00	25.00	4.00
4.003	GT104.3217.010.12.20.L	2.00	0.10	32	1.95	1.70	0.30	12.00	30.00	4.00
4.004	GT104.3217.010.17.20.L	2.00	0.10	32	1.95	1.70	0.70	17.00	35.00	4.00
4.005	GT104.3226.005.07.30.L	3.00	0.05	32	1.95	2.60	0.70	7.00	25.00	4.00
4.006	GT104.3226.005.12.30.L	3.00	0.05	32	1.95	2.60	0.70	12.00	30.00	4.00
4.007	GT104.3226.005.17.30.L	3.00	0.05	32	1.95	2.60	0.70	17.00	35.00	4.00
4.008	GT104.3226.005.22.30.L	3.00	0.05	32	1.95	2.60	0.70	22.00	40.00	4.00
4.009	GT104.3226.010.07.30.L	3.00	0.10	32	1.95	2.60	0.70	7.00	25.00	4.00
4.010	GT104.3226.010.12.30.L	3.00	0.10	32	1.95	2.60	0.70	12.00	30.00	4.00
4.011	GT104.3226.010.17.30.L	3.00	0.10	32	1.95	2.60	0.70	17.00	35.00	4.00
4.012	GT104.3226.010.22.30.L	3.00	0.10	32	1.95	2.60	0.70	22.00	40.00	4.00



Article no. **25107** **25109** **25111** **25113**

Cutting direction    

Code no.	Description	D min	R	W1	f	a	t max	La	Lg	D h6
		mm	mm	°	mm	mm	mm	mm	mm	mm
4.013	GT104.3237.010.12.40.L	4.00	0.10	32	1.70	3.70	1.00	12.00	30.00	4.00
4.014	GT104.3237.010.17.40.L	4.00	0.10	32	1.70	3.70	1.00	17.00	35.00	4.00
4.015	GT104.3237.010.22.40.L	4.00	0.10	32	1.70	3.70	1.00	22.00	40.00	4.00
4.016	GT104.3237.010.27.40.L	4.00	0.10	32	1.70	3.70	1.00	27.00	45.00	4.00
4.017	GT104.3237.010.32.40.L	4.00	0.10	32	1.70	3.70	1.00	32.00	50.00	4.00
4.018	GT104.3237.015.12.40.L	4.00	0.15	32	1.70	3.70	1.00	12.00	30.00	4.00
4.019	GT104.3237.015.17.40.L	4.00	0.15	32	1.70	3.70	1.00	17.00	35.00	4.00
4.020	GT104.3237.015.22.40.L	4.00	0.15	32	1.70	3.70	1.00	22.00	40.00	4.00
4.021	GT104.3237.015.27.40.L	4.00	0.15	32	1.70	3.70	1.00	27.00	45.00	4.00
4.022	GT104.3237.015.32.40.L	4.00	0.15	32	1.70	3.70	1.00	32.00	50.00	4.00



Cutting insert for boring out and chamfering

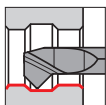

• from hole-Ø 2, 45° both sides

for tool holders type GH104/GB104 see from page 16

GÜHRING NAVIGATOR

Cutting data page 94

Tool material	Solid carbide			
Type	GT 104	GT 104	GT 104	GT 104
Surface	S	a	C	○
	TiN	TiAlN-nanoA	TiCN	bright

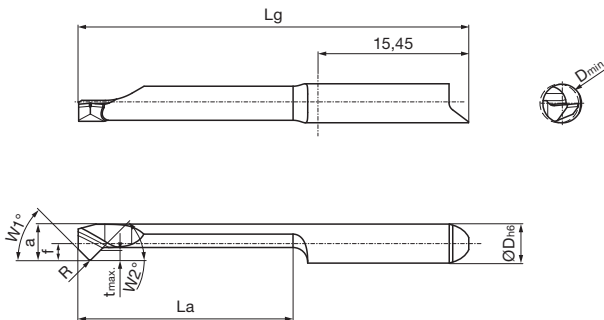

Right hand version shown
Left hand version mirror image

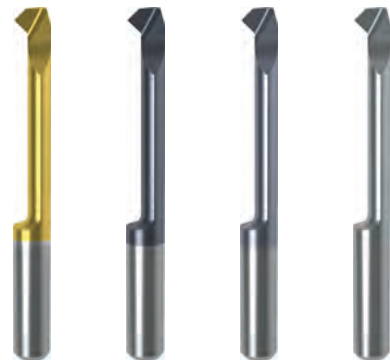

Article no.	25114	25116	25118	25120
Cutting direction	(R)	(R)	(R)	(R)

Code no.	Description	D min	R	W1	W2	f	a	t max	La	Lg	D h6
		mm	mm	°	°	mm	mm	mm	mm	mm	mm
4.001	GT104.4518.010.04.20.R	2.00	0.10	45	45	1.95	1.80	0.50	4.00	25.00	4.00
4.002	GT104.4518.010.07.20.R	2.00	0.10	45	45	1.95	1.80	0.50	7.00	25.00	4.00
4.003	GT104.4518.010.12.20.R	2.00	0.10	45	45	1.95	1.80	0.50	12.00	30.00	4.00
4.004	GT104.4518.010.17.20.R	2.00	0.10	45	45	1.95	1.80	0.50	17.00	35.00	4.00
4.005	GT104.4527.010.07.30.R	3.00	0.10	45	45	1.95	2.70	0.70	7.00	25.00	4.00
4.006	GT104.4527.010.12.30.R	3.00	0.10	45	45	1.95	2.70	0.70	12.00	30.00	4.00
4.007	GT104.4527.010.17.30.R	3.00	0.10	45	45	1.95	2.70	0.70	17.00	35.00	4.00
4.008	GT104.4527.010.22.30.R	3.00	0.10	45	45	1.95	2.70	0.70	22.00	40.00	4.00
4.009	GT104.4537.015.12.40.R	4.00	0.15	45	45	1.70	3.70	1.00	12.00	30.00	4.00
4.010	GT104.4537.015.17.40.R	4.00	0.15	45	45	1.70	3.70	1.00	17.00	35.00	4.00
4.011	GT104.4537.015.22.40.R	4.00	0.15	45	45	1.70	3.70	1.00	22.00	40.00	4.00
4.012	GT104.4537.015.27.40.R	4.00	0.15	45	45	1.70	3.70	1.00	27.00	45.00	4.00
4.013	GT104.4537.015.32.40.R	4.00	0.15	45	45	1.70	3.70	1.00	32.00	50.00	4.00

Article no.	25115	25117	25119	25121
Cutting direction	(L)	(L)	(L)	(L)

Code no.	Description	D min	R	W1	W2	f	a	t max	La	Lg	D h6
		mm	mm	°	°	mm	mm	mm	mm	mm	mm
4.001	GT104.4518.010.04.20.L	2.00	0.10	45	45	1.95	1.80	0.50	4.00	25.00	4.00
4.002	GT104.4518.010.07.20.L	2.00	0.10	45	45	1.95	1.80	0.50	7.00	25.00	4.00
4.003	GT104.4518.010.12.20.L	2.00	0.10	45	45	1.95	1.80	0.50	12.00	30.00	4.00
4.004	GT104.4518.010.17.20.L	2.00	0.10	45	45	1.95	1.80	0.50	17.00	35.00	4.00
4.005	GT104.4527.010.07.30.L	3.00	0.10	45	45	1.95	2.70	0.70	7.00	25.00	4.00
4.006	GT104.4527.010.12.30.L	3.00	0.10	45	45	1.95	2.70	0.70	12.00	30.00	4.00
4.007	GT104.4527.010.17.30.L	3.00	0.10	45	45	1.95	2.70	0.70	17.00	35.00	4.00
4.008	GT104.4527.010.22.30.L	3.00	0.10	45	45	1.95	2.70	0.70	22.00	40.00	4.00
4.009	GT104.4537.015.12.40.L	4.00	0.15	45	45	1.70	3.70	1.00	12.00	30.00	4.00
4.010	GT104.4537.015.17.40.L	4.00	0.15	45	45	1.70	3.70	1.00	17.00	35.00	4.00
4.011	GT104.4537.015.22.40.L	4.00	0.15	45	45	1.70	3.70	1.00	22.00	40.00	4.00
4.012	GT104.4537.015.27.40.L	4.00	0.15	45	45	1.70	3.70	1.00	27.00	45.00	4.00
4.013	GT104.4537.015.32.40.L	4.00	0.15	45	45	1.70	3.70	1.00	32.00	50.00	4.00

Cutting insert for internal grooving, straight slots

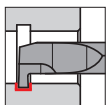

• from hole-Ø 1, grooving depth up to 1 mm

for tool holders type GH104/GB104 see from page 16

Tool material	Solid carbide			
	GE 104	GE 104	GE 104	GE 104
Type	GE 104	GE 104	GE 104	GE 104
Surface	S	a	C	○
	TiN	TiAlN-nanoA	TiCN	bright

GUHRING NAVIGATOR

Cutting data page 94

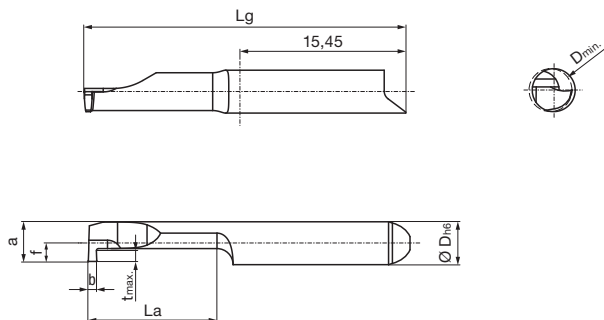

Right hand version shown
Left hand version mirror image



Article no.	25124	25126	25128	25130
Cutting direction	(R)	(R)	(R)	(R)

Code no.	Description	D min	b	f	a	t max	La	Lg	D h6
		mm	mm	mm	mm	mm	mm	mm	mm
4.001	GE104.0030.000.04.10.R	1.00	0.30	1.95	0.85	0.20	4.00	25.00	4.00
4.002	GE104.0030.000.07.10.R	1.00	0.30	1.95	0.85	0.20	7.00	25.00	4.00
4.003	GE104.0040.000.04.15.R	1.50	0.40	1.95	1.30	0.40	4.00	25.00	4.00
4.004	GE104.0040.000.07.15.R	1.50	0.40	1.95	1.30	0.40	7.00	25.00	4.00
4.005	GE104.0040.000.12.15.R	1.50	0.40	1.95	1.30	0.40	12.00	30.00	4.00
4.006	GE104.0050.000.04.20.R	2.00	0.50	1.95	1.80	0.50	4.00	25.00	4.00
4.007	GE104.0050.000.07.20.R	2.00	0.50	1.95	1.80	0.50	7.00	25.00	4.00
4.008	GE104.0050.000.12.20.R	2.00	0.50	1.95	1.80	0.50	12.00	30.00	4.00
4.009	GE104.0050.000.17.20.R	2.00	0.50	1.95	1.80	0.50	17.00	35.00	4.00
4.010	GE104.0070.000.07.30.R	3.00	0.70	1.95	2.70	0.70	7.00	25.00	4.00
4.011	GE104.0070.000.12.30.R	3.00	0.70	1.95	2.70	0.70	12.00	30.00	4.00
4.012	GE104.0070.000.17.30.R	3.00	0.70	1.95	2.70	0.70	17.00	35.00	4.00
4.013	GE104.0070.000.22.30.R	3.00	0.70	1.95	2.70	0.70	22.00	40.00	4.00
4.014	GE104.0079.000.12.40.R	4.00	0.79	1.70	3.70	1.00	12.00	30.00	4.00
4.015	GE104.0079.000.17.40.R	4.00	0.79	1.70	3.70	1.00	17.00	35.00	4.00
4.016	GE104.0079.000.22.40.R	4.00	0.79	1.70	3.70	1.00	22.00	40.00	4.00
4.017	GE104.0079.000.27.40.R	4.00	0.79	1.70	3.70	1.00	27.00	45.00	4.00
4.018	GE104.0079.000.32.40.R	4.00	0.79	1.70	3.70	1.00	32.00	50.00	4.00
4.019	GE104.0100.000.12.40.R	4.00	1.00	1.70	3.70	1.00	12.00	30.00	4.00
4.020	GE104.0100.000.17.40.R	4.00	1.00	1.70	3.70	1.00	17.00	35.00	4.00
4.021	GE104.0100.000.22.40.R	4.00	1.00	1.70	3.70	1.00	22.00	40.00	4.00
4.022	GE104.0100.000.27.40.R	4.00	1.00	1.70	3.70	1.00	27.00	45.00	4.00
4.023	GE104.0100.000.32.40.R	4.00	1.00	1.70	3.70	1.00	32.00	50.00	4.00
4.024	GE104.0150.000.12.40.R	4.00	1.50	1.70	3.70	1.00	12.00	30.00	4.00
4.025	GE104.0150.000.17.40.R	4.00	1.50	1.70	3.70	1.00	17.00	35.00	4.00
4.026	GE104.0150.000.22.40.R	4.00	1.50	1.70	3.70	1.00	22.00	40.00	4.00
4.027	GE104.0150.000.27.40.R	4.00	1.50	1.70	3.70	1.00	27.00	45.00	4.00
4.028	GE104.0150.000.32.40.R	4.00	1.50	1.70	3.70	1.00	32.00	50.00	4.00

Article no.	25125	25127	25129	25131
Cutting direction	(L)	(L)	(L)	(L)

Code no.	Description	D min	b	f	a	t max	La	Lg	D h6
		mm	mm	mm	mm	mm	mm	mm	mm
4.001	GE104.0030.000.04.10.L	1.00	0.30	1.95	0.85	0.20	4.00	25.00	4.00
4.002	GE104.0030.000.07.10.L	1.00	0.30	1.95	0.85	0.20	7.00	25.00	4.00
4.003	GE104.0040.000.04.15.L	1.50	0.40	1.95	1.30	0.40	4.00	25.00	4.00
4.004	GE104.0040.000.07.15.L	1.50	0.40	1.95	1.30	0.40	7.00	25.00	4.00
4.005	GE104.0040.000.12.15.L	1.50	0.40	1.95	1.30	0.40	12.00	30.00	4.00
4.006	GE104.0050.000.04.20.L	2.00	0.50	1.95	1.80	0.50	4.00	25.00	4.00

Article no. **25125** **25127** **25129** **25131**Cutting direction    

Code no.	Description	D min	b	f	a	t max	La	Lg	D h6
		mm	mm	mm	mm	mm	mm	mm	mm
4.007	GE104.0050.000.07.20.L	2.00	0.50	1.95	1.80	0.50	7.00	25.00	4.00
4.008	GE104.0050.000.12.20.L	2.00	0.50	1.95	1.80	0.50	12.00	30.00	4.00
4.009	GE104.0050.000.17.20.L	2.00	0.50	1.95	1.80	0.50	17.00	35.00	4.00
4.010	GE104.0070.000.07.30.L	3.00	0.70	1.95	2.70	0.70	7.00	25.00	4.00
4.011	GE104.0070.000.12.30.L	3.00	0.70	1.95	2.70	0.70	12.00	30.00	4.00
4.012	GE104.0070.000.17.30.L	3.00	0.70	1.95	2.70	0.70	17.00	35.00	4.00
4.013	GE104.0070.000.22.30.L	3.00	0.70	1.95	2.70	0.70	22.00	40.00	4.00
4.014	GE104.0079.000.12.40.L	4.00	0.79	1.70	3.70	1.00	12.00	30.00	4.00
4.015	GE104.0079.000.17.40.L	4.00	0.79	1.70	3.70	1.00	17.00	35.00	4.00
4.016	GE104.0079.000.22.40.L	4.00	0.79	1.70	3.70	1.00	22.00	40.00	4.00
4.017	GE104.0079.000.27.40.L	4.00	0.79	1.70	3.70	1.00	27.00	45.00	4.00
4.018	GE104.0079.000.32.40.L	4.00	0.79	1.70	3.70	1.00	32.00	50.00	4.00
4.019	GE104.0100.000.12.40.L	4.00	1.00	1.70	3.70	1.00	12.00	30.00	4.00
4.020	GE104.0100.000.17.40.L	4.00	1.00	1.70	3.70	1.00	17.00	35.00	4.00
4.021	GE104.0100.000.22.40.L	4.00	1.00	1.70	3.70	1.00	22.00	40.00	4.00
4.022	GE104.0100.000.27.40.L	4.00	1.00	1.70	3.70	1.00	27.00	45.00	4.00
4.023	GE104.0100.000.32.40.L	4.00	1.00	1.70	3.70	1.00	32.00	50.00	4.00
4.024	GE104.0150.000.12.40.L	4.00	1.50	1.70	3.70	1.00	12.00	30.00	4.00
4.025	GE104.0150.000.17.40.L	4.00	1.50	1.70	3.70	1.00	17.00	35.00	4.00
4.026	GE104.0150.000.22.40.L	4.00	1.50	1.70	3.70	1.00	22.00	40.00	4.00
4.027	GE104.0150.000.27.40.L	4.00	1.50	1.70	3.70	1.00	27.00	45.00	4.00
4.028	GE104.0150.000.32.40.L	4.00	1.50	1.70	3.70	1.00	32.00	50.00	4.00

Cutting insert for internal grooving, full radius slots

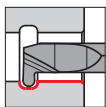

• from hole-Ø 3, full radius R0.4-R0.58

for tool holders type GH104/GB104 see from page 16

Tool material	Solid carbide			
Type	GE 104	GE 104	GE 104	GE 104
Surface	S	a	C	○
	TiN	TiAlN-nanoA	TiCN	bright

GUHRING NAVIGATOR

Cutting data page 94

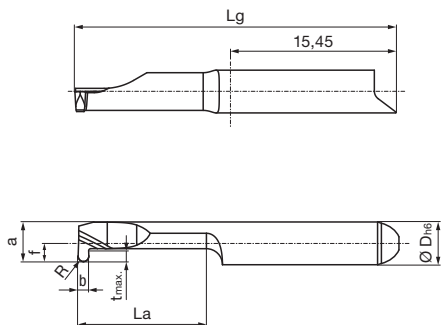

Right hand version shown
Left hand version mirror image

Article no.	25132	25134	25136	25138
Cutting direction	(R)	(R)	(R)	(R)

Code no.	Description	D min	b	R	f	a	t max	La	Lg	D h6
		mm	mm	mm	mm	mm	mm	mm	mm	mm
4.001	GE104.0080.040.07.30.R	3.00	0.80	0.40	1.95	2.70	0.70	7.00	25.00	4.00
4.002	GE104.0080.040.12.30.R	3.00	0.80	0.40	1.95	2.70	0.70	12.00	30.00	4.00
4.003	GE104.0080.040.17.30.R	3.00	0.80	0.40	1.95	2.70	0.70	17.00	35.00	4.00
4.004	GE104.0080.040.22.30.R	3.00	0.80	0.40	1.95	2.70	0.70	22.00	40.00	4.00
4.005	GE104.0100.050.12.40.R	4.00	1.00	0.50	1.70	3.70	1.00	12.00	30.00	4.00
4.006	GE104.0100.050.17.40.R	4.00	1.00	0.50	1.70	3.70	1.00	17.00	35.00	4.00
4.007	GE104.0100.050.22.40.R	4.00	1.00	0.50	1.70	3.70	1.00	22.00	40.00	4.00
4.008	GE104.0100.050.27.40.R	4.00	1.00	0.50	1.70	3.70	1.00	27.00	45.00	4.00
4.009	GE104.0100.050.32.40.R	4.00	1.00	0.50	1.70	3.70	1.00	32.00	50.00	4.00
4.010	GE104.0117.058.12.40.R	4.00	1.17	0.58	1.70	3.70	1.00	12.00	30.00	4.00
4.011	GE104.0117.058.17.40.R	4.00	1.17	0.58	1.70	3.70	1.00	17.00	35.00	4.00
4.012	GE104.0117.058.22.40.R	4.00	1.17	0.58	1.70	3.70	1.00	22.00	40.00	4.00
4.013	GE104.0117.058.27.40.R	4.00	1.17	0.58	1.70	3.70	1.00	27.00	45.00	4.00
4.014	GE104.0117.058.32.40.R	4.00	1.17	0.58	1.70	3.70	1.00	32.00	50.00	4.00

Article no.	25133	25135	25137	25139
Cutting direction	(L)	(L)	(L)	(L)

Code no.	Description	D min	b	R	f	a	t max	La	Lg	D h6
		mm	mm	mm	mm	mm	mm	mm	mm	mm
4.001	GE104.0080.040.07.30.L	3.00	0.80	0.40	1.95	2.70	0.70	7.00	25.00	4.00
4.002	GE104.0080.040.12.30.L	3.00	0.80	0.40	1.95	2.70	0.70	12.00	30.00	4.00
4.003	GE104.0080.040.17.30.L	3.00	0.80	0.40	1.95	2.70	0.70	17.00	35.00	4.00
4.004	GE104.0080.040.22.30.L	3.00	0.80	0.40	1.95	2.70	0.70	22.00	40.00	4.00
4.005	GE104.0100.050.12.40.L	4.00	1.00	0.50	1.70	3.70	1.00	12.00	30.00	4.00
4.006	GE104.0100.050.17.40.L	4.00	1.00	0.50	1.70	3.70	1.00	17.00	35.00	4.00
4.007	GE104.0100.050.22.40.L	4.00	1.00	0.50	1.70	3.70	1.00	22.00	40.00	4.00
4.008	GE104.0100.050.27.40.L	4.00	1.00	0.50	1.70	3.70	1.00	27.00	45.00	4.00
4.009	GE104.0100.050.32.40.L	4.00	1.00	0.50	1.70	3.70	1.00	32.00	50.00	4.00
4.010	GE104.0117.058.12.40.L	4.00	1.17	0.58	1.70	3.70	1.00	12.00	30.00	4.00
4.011	GE104.0117.058.17.40.L	4.00	1.17	0.58	1.70	3.70	1.00	17.00	35.00	4.00
4.012	GE104.0117.058.22.40.L	4.00	1.17	0.58	1.70	3.70	1.00	22.00	40.00	4.00
4.013	GE104.0117.058.27.40.L	4.00	1.17	0.58	1.70	3.70	1.00	27.00	45.00	4.00
4.014	GE104.0117.058.32.40.L	4.00	1.17	0.58	1.70	3.70	1.00	32.00	50.00	4.00



Cutting insert for internal pre-grooving and chamfering

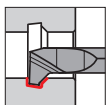

• from hole-Ø 2, 45° chamfer

Tool material	Solid carbide			
Type	GV 104	GV 104	GV 104	GV 104
Surface	S	a	C	○
	TiN	TiAlN-nanoA	TiCN	bright

for tool holders type GH104/GB104 see from page 16

GUHRING NAVIGATOR

Cutting data page 94

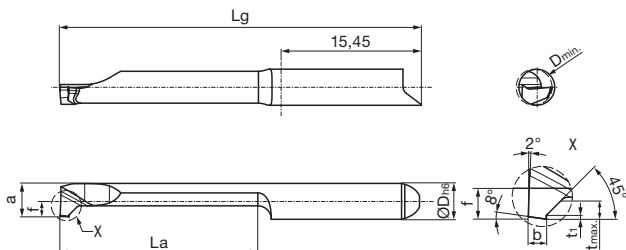

Right hand version shown
Left hand version mirror image

Article no.	25140	25142	25144	25146
Cutting direction	(R)	(R)	(R)	(R)

Code no.	Description	D min	b	f	t1	a	t max	Lg	La	D h6
		mm	mm	mm	mm	mm	mm	mm	mm	mm
4.001	GV104.0807.045.04.20.R	2.00	0.70	1.95	0.20	1.80	0.50	25.00	4.00	4.00
4.002	GV104.0807.045.07.20.R	2.00	0.70	1.95	0.20	1.80	0.50	25.00	7.00	4.00
4.003	GV104.0807.045.12.20.R	2.00	0.70	1.95	0.20	1.80	0.50	30.00	12.00	4.00
4.004	GV104.0807.045.17.20.R	2.00	0.70	1.95	0.20	1.80	0.50	35.00	17.00	4.00
4.005	GV104.0807.045.07.30.R	3.00	0.70	1.95	0.20	2.70	0.70	25.00	7.00	4.00
4.006	GV104.0807.045.12.30.R	3.00	0.70	1.95	0.20	2.70	0.70	30.00	12.00	4.00
4.007	GV104.0807.045.17.30.R	3.00	0.70	1.95	0.20	2.70	0.70	35.00	17.00	4.00
4.008	GV104.0807.045.22.30.R	3.00	0.70	1.95	0.20	2.70	0.70	40.00	22.00	4.00
4.009	GV104.0810.045.12.40.R	4.00	1.00	1.70	0.20	3.70	1.00	30.00	12.00	4.00
4.010	GV104.0810.045.17.40.R	4.00	1.00	1.70	0.20	3.70	1.00	35.00	17.00	4.00
4.011	GV104.0810.045.22.40.R	4.00	1.00	1.70	0.20	3.70	1.00	40.00	22.00	4.00
4.012	GV104.0810.045.27.40.R	4.00	1.00	1.70	0.20	3.70	1.00	45.00	27.00	4.00
4.013	GV104.0810.045.32.40.R	4.00	1.00	1.70	0.20	3.70	1.00	50.00	32.00	4.00

Article no.	25141	25143	25145	25147
Cutting direction	(L)	(L)	(L)	(L)

Code no.	Description	D min	b	f	t1	a	t max	La	Lg	D h6
		mm	mm	mm	mm	mm	mm	mm	mm	mm
4.001	GV104.0807.045.04.20.L	2.00	0.70	1.95	0.20	1.80	0.50	4.00	25.00	4.00
4.002	GV104.0807.045.07.20.L	2.00	0.70	1.95	0.20	1.80	0.50	7.00	25.00	4.00
4.003	GV104.0807.045.12.20.L	2.00	0.70	1.95	0.20	1.80	0.50	12.00	30.00	4.00
4.004	GV104.0807.045.17.20.L	2.00	0.70	1.95	0.20	1.80	0.50	17.00	35.00	4.00
4.005	GV104.0807.045.07.30.L	3.00	0.70	1.95	0.20	2.70	0.70	7.00	25.00	4.00
4.006	GV104.0807.045.12.30.L	3.00	0.70	1.95	0.20	2.70	0.70	12.00	30.00	4.00
4.007	GV104.0807.045.17.30.L	3.00	0.70	1.95	0.20	2.70	0.70	17.00	35.00	4.00
4.008	GV104.0807.045.22.30.L	3.00	0.70	1.95	0.20	2.70	0.70	22.00	40.00	4.00
4.009	GV104.0810.045.12.40.L	4.00	1.00	1.70	0.20	3.70	1.00	12.00	30.00	4.00
4.010	GV104.0810.045.17.40.L	4.00	1.00	1.70	0.20	3.70	1.00	17.00	35.00	4.00
4.011	GV104.0810.045.22.40.L	4.00	1.00	1.70	0.20	3.70	1.00	22.00	40.00	4.00
4.012	GV104.0810.045.27.40.L	4.00	1.00	1.70	0.20	3.70	1.00	27.00	45.00	4.00
4.013	GV104.0810.045.32.40.L	4.00	1.00	1.70	0.20	3.70	1.00	32.00	50.00	4.00

Cutting insert for axial grooving bores, straight slots

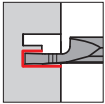

• from hole-Ø 4, grooving depth up to 5 mm

for tool holders type GH104/GB104 see from page 16

Tool material	Solid carbide			
Type	GA 104	GA 104	GA 104	GA 104
Surface				
	TiN	TiAlN-nanoA	TiCN	bright

GUHRING NAVIGATOR

Cutting data page 94

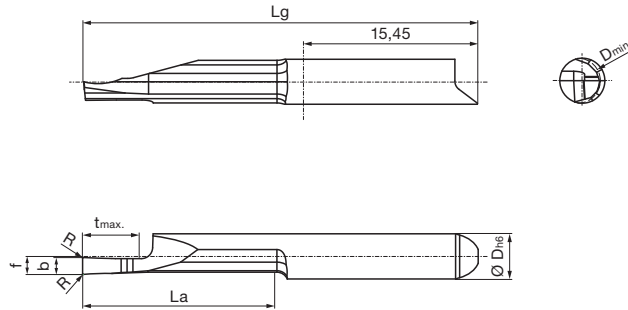

Right hand version shown
Left hand version mirror image



Article no.	25188	25190	25192	25194
Cutting direction				

Code no.	Description	D min	b	R	f	t max	La	Lg	D h6
		mm	mm	mm	mm	mm	mm	mm	mm
4.001	GA104.0100.005.12.40.R	4.00	1.00	0.05	1.60	2.00	12.00	30.00	4.00
4.002	GA104.0100.005.17.40.R	4.00	1.00	0.05	1.60	2.00	17.00	35.00	4.00
4.003	GA104.0150.005.12.40.R	4.00	1.50	0.05	1.60	3.00	12.00	30.00	4.00
4.004	GA104.0150.005.17.40.R	4.00	1.50	0.05	1.60	3.00	17.00	35.00	4.00
4.005	GA104.0200.005.12.50.R	5.00	2.00	0.05	1.60	5.00	12.00	30.00	4.00
4.006	GA104.0200.005.17.50.R	5.00	2.00	0.05	1.60	5.00	17.00	35.00	4.00

Article no.	25189	25191	25193	25195
Cutting direction				

Code no.	Description	D min	b	R	f	t max	La	Lg	D h6
		mm	mm	mm	mm	mm	mm	mm	mm
4.001	GA104.0100.005.12.40.L	4.00	1.00	0.05	1.60	2.00	12.00	30.00	4.00
4.002	GA104.0100.005.17.40.L	4.00	1.00	0.05	1.60	2.00	17.00	35.00	4.00
4.003	GA104.0150.005.12.40.L	4.00	1.50	0.05	1.60	3.00	12.00	30.00	4.00
4.004	GA104.0150.005.17.40.L	4.00	1.50	0.05	1.60	3.00	17.00	35.00	4.00
4.005	GA104.0200.005.12.50.L	5.00	2.00	0.05	1.60	5.00	12.00	30.00	4.00
4.006	GA104.0200.005.17.50.L	5.00	2.00	0.05	1.60	5.00	17.00	35.00	4.00



Cutting insert for axial grooving bores, full radius slots

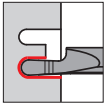

• from hole-Ø 6, grooving depth up to 5 mm

for tool holders type GH104/GB104 see from page 16

GUHRING NAVIGATOR

Cutting data page 94

Tool material	Solid carbide			
Type	GA 104	GA 104	GA 104	GA 104
Surface				
	TiN	TiAlN-nanoA	TiCN	bright

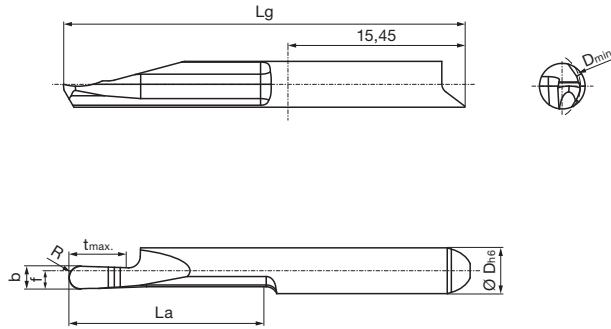

Right hand version shown
Left hand version mirror image



Article no.	25196	25198	25200	25202
Cutting direction				

Code no.	Description	D min	b	R	f	t max	La	Lg	D h6
		mm	mm	mm	mm	mm	mm	mm	mm
4.001	GA104.0100.050.12.60.R	6.00	1.00	0.50	1.60	2.00	12.00	30.00	4.00
4.002	GA104.0100.050.17.60.R	6.00	1.00	0.50	1.60	2.00	17.00	35.00	4.00
4.003	GA104.0150.075.12.60.R	6.00	1.50	0.75	1.60	3.00	12.00	30.00	4.00
4.004	GA104.0150.075.17.60.R	6.00	1.50	0.75	1.60	3.00	17.00	35.00	4.00
4.005	GA104.0200.100.12.60.R	6.00	2.00	1.00	1.60	5.00	12.00	30.00	4.00
4.006	GA104.0200.100.17.60.R	6.00	2.00	1.00	1.60	5.00	17.00	35.00	4.00

Article no.	25197	25199	25201	25203
Cutting direction				

Code no.	Description	D min	b	R	f	t max	La	Lg	D h6
		mm	mm	mm	mm	mm	mm	mm	mm
4.001	GA104.0100.050.12.60.L	6.00	1.00	0.50	1.60	2.00	12.00	30.00	4.00
4.002	GA104.0100.050.17.60.L	6.00	1.00	0.50	1.60	2.00	17.00	35.00	4.00
4.003	GA104.0150.075.12.60.L	6.00	1.50	0.75	1.60	3.00	12.00	30.00	4.00
4.004	GA104.0150.075.17.60.L	6.00	1.50	0.75	1.60	3.00	17.00	35.00	4.00
4.005	GA104.0200.100.12.60.L	6.00	2.00	1.00	1.60	5.00	12.00	30.00	4.00
4.006	GA104.0200.100.17.60.L	6.00	2.00	1.00	1.60	5.00	17.00	35.00	4.00



System 104

Cutting insert for axial grooving studs, straight slots

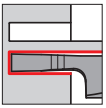

• from hole-Ø 4, grooving depth up to 5 mm

for tool holders type GH104/GB104 see from page 16

Tool material	Solid carbide			
Type	GA 104	GA 104	GA 104	GA 104
Surface				
	TiN	TiAlN-nanoA	TiCN	bright

GUHRING NAVIGATOR

Cutting data page 94

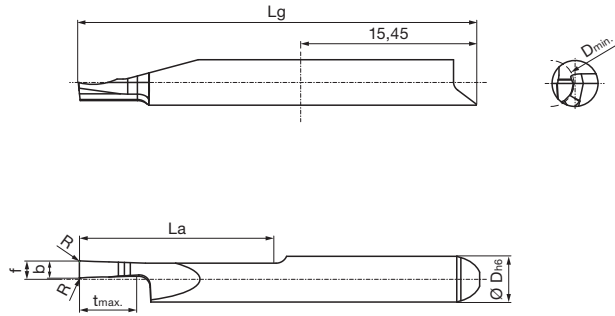

Right hand version shown
Left hand version mirror image



Article no.	25204	25206	25208	25210
Cutting direction				

Code no.	Description	D min	b	R	f	t max	La	Lg	D h6
		mm	mm	mm	mm	mm	mm	mm	mm
4.001	GA104.Z100.005.12.40.R	4.00	1.00	0.05	1.60	2.00	12.00	30.00	4.00
4.002	GA104.Z100.005.17.40.R	4.00	1.00	0.05	1.60	2.00	17.00	35.00	4.00
4.003	GA104.Z150.005.12.40.R	4.00	1.50	0.05	1.60	3.00	12.00	30.00	4.00
4.004	GA104.Z150.005.17.40.R	4.00	1.50	0.05	1.60	3.00	17.00	35.00	4.00
4.005	GA104.Z200.005.12.50.R	5.00	2.00	0.05	1.60	5.00	12.00	30.00	4.00
4.006	GA104.Z200.005.17.50.R	5.00	2.00	0.05	1.60	5.00	17.00	35.00	4.00

Article no.	25205	25207	25209	25211
Cutting direction				

Code no.	Description	D min	b	R	f	t max	La	Lg	D h6
		mm	mm	mm	mm	mm	mm	mm	mm
4.001	GA104.Z100.005.12.40.L	4.00	1.00	0.05	1.60	2.00	12.00	30.00	4.00
4.002	GA104.Z100.005.17.40.L	4.00	1.00	0.05	1.60	2.00	17.00	35.00	4.00
4.003	GA104.Z150.005.12.40.L	4.00	1.50	0.05	1.60	3.00	12.00	30.00	4.00
4.004	GA104.Z150.005.17.40.L	4.00	1.50	0.05	1.60	3.00	17.00	35.00	4.00
4.005	GA104.Z200.005.12.50.L	5.00	2.00	0.05	1.60	5.00	12.00	30.00	4.00
4.006	GA104.Z200.005.17.50.L	5.00	2.00	0.05	1.60	5.00	17.00	35.00	4.00



Cutting insert for axial grooving studs, full radius slots



• from hole-Ø 6, grooving depth up to 5 mm

for tool holders type GH104/GB104 see from page 16

GUHRING NAVIGATOR

Cutting data page 94

Tool material	Solid carbide			
Type	GA 104	GA 104	GA 104	GA 104
Surface				
	TiN	TiAlN-nanoA	TiCN	bright

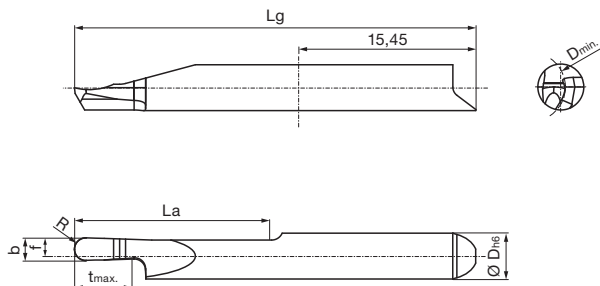

Right hand version shown
Left hand version mirror image

Article no.	25212	25214	25216	25218
Cutting direction				

Code no.	Description	D min	b	R	f	t max	La	Lg	D h6
		mm	mm	mm	mm	mm	mm	mm	mm
4.001	GA104.Z100.050.12.60.R	6.00	1.00	0.50	1.60	2.00	12.00	30.00	4.00
4.002	GA104.Z100.050.17.60.R	6.00	1.00	0.50	1.60	2.00	17.00	35.00	4.00
4.003	GA104.Z150.075.12.60.R	6.00	1.50	0.75	1.60	3.00	12.00	30.00	4.00
4.004	GA104.Z150.075.17.60.R	6.00	1.50	0.75	1.60	3.00	17.00	35.00	4.00
4.005	GA104.Z200.100.12.60.R	6.00	2.00	1.00	1.60	5.00	12.00	30.00	4.00
4.006	GA104.Z200.100.17.60.R	6.00	2.00	1.00	1.60	5.00	17.00	35.00	4.00

Article no.	25213	25215	25217	25219
Cutting direction				

Code no.	Description	D min	b	R	f	t max	La	Lg	D h6
		mm	mm	mm	mm	mm	mm	mm	mm
4.001	GA104.Z100.050.12.60.L	6.00	1.00	0.50	1.60	2.00	12.00	30.00	4.00
4.002	GA104.Z100.050.17.60.L	6.00	1.00	0.50	1.60	2.00	17.00	35.00	4.00
4.003	GA104.Z150.075.12.60.L	6.00	1.50	0.75	1.60	3.00	12.00	30.00	4.00
4.004	GA104.Z150.075.17.60.L	6.00	1.50	0.75	1.60	3.00	17.00	35.00	4.00
4.005	GA104.Z200.100.12.60.L	6.00	2.00	1.00	1.60	5.00	12.00	30.00	4.00
4.006	GA104.Z200.100.17.60.L	6.00	2.00	1.00	1.60	5.00	17.00	35.00	4.00



System 104

Cutting insert for axial chamfering bores

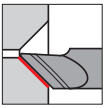

• from hole-Ø 0.8, 45°/60°/75° chamfer angle

for tool holders type GH104/GB104 see from page 16

Tool material	Solid carbide			
Type	GA 104	GA 104	GA 104	GA 104
Surface	S	a	C	○
	TiN	TiAlN-nanoA	TiCN	bright

GUHRING NAVIGATOR

Cutting data page 94

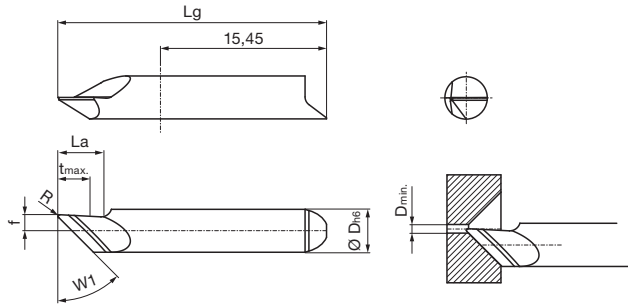

Right hand version shown
Left hand version mirror image



Article no.	25220	25222	25224	25226
Cutting direction	(R)	(R)	(R)	(R)

Code no.	Description	D min	R	W1	f	t max	La	Lg	D h6
		mm	mm	°	mm	mm	mm	mm	mm
4.001	GA104.F045.015.04.08.R	0.80	0.15	45.00	1.50	3.00	4.00	25.00	4.00
4.002	GA104.F060.015.04.08.R	0.80	0.15	60.00	0.50	3.50	4.00	25.00	4.00
4.003	GA104.F075.015.04.08.R	0.80	0.15	75.00	0.50	2.00	4.00	25.00	4.00

Article no.	25221	25223	25225	25227
Cutting direction	(L)	(L)	(L)	(L)

Code no.	Description	D min	R	W1	f	t max	La	Lg	D h6
		mm	mm	°	mm	mm	mm	mm	mm
4.001	GA104.F045.015.04.08.L	0.80	0.15	45.00	1.50	3.00	4.00	25.00	4.00
4.002	GA104.F060.015.04.08.L	0.80	0.15	60.00	0.50	3.50	4.00	25.00	4.00
4.003	GA104.F075.015.04.08.L	0.80	0.15	75.00	0.50	2.00	4.00	25.00	4.00



Cutting insert for internal threading, part profile - metric standard threads

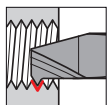

• from hole-Ø 1.55, pitch P = 0.4-1.0

for tool holders type GH104/GB104 see from page 16

Tool material	Solid carbide			
	GG 104	GG 104	GG 104	GG 104
Type	GG 104	GG 104	GG 104	GG 104
Surface	S TiN	a TiAlN-nanoA	C TiCN	○ bright

System 104

GUHRING NAVIGATOR

Cutting data page 94

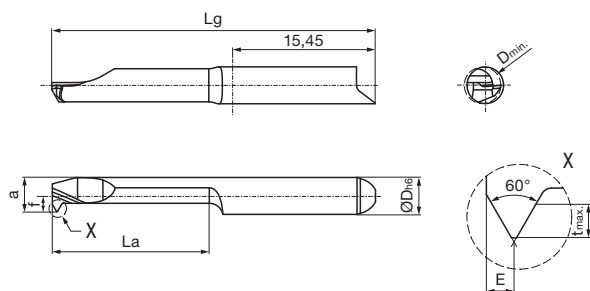

Right hand version shown
Left hand version mirror image

Article no.	25148	25150	25152	25154
Cutting direction	(R)	(R)	(R)	(R)

Code no.	Description	G	P	D min	f	t max	a	E	La	Lg	D h6
				mm	mm	mm	mm	mm	mm	mm	mm
4.001	GG104.TM02.040.04.15.R	M2/M2,5	0,40-0,45	1.55	1.95	0.25	1.40	0.25	4.00	25.00	4.00
4.002	GG104.TM02.040.07.15.R	M2/M2,5	0,40-0,45	1.55	1.95	0.25	1.40	0.25	7.00	25.00	4.00
4.003	GG104.TM02.040.12.15.R	M2/M2,5	0,40-0,45	1.55	1.95	0.25	1.40	0.25	12.00	30.00	4.00
4.004	GG104.TM03.050.04.25.R	M3	0,50	2.50	1.95	0.30	2.20	0.30	4.00	25.00	4.00
4.005	GG104.TM03.050.07.25.R	M3	0,50	2.50	1.95	0.30	2.20	0.30	7.00	25.00	4.00
4.006	GG104.TM03.050.12.25.R	M3	0,50	2.50	1.95	0.30	2.20	0.30	12.00	30.00	4.00
4.007	GG104.TM04.070.07.33.R	M4	0,70	3.30	1.95	0.40	3.00	0.40	7.00	25.00	4.00
4.008	GG104.TM04.070.12.33.R	M4	0,70	3.30	1.95	0.40	3.00	0.40	12.00	30.00	4.00
4.009	GG104.TM04.070.17.33.R	M4	0,70	3.30	1.95	0.40	3.00	0.40	17.00	35.00	4.00
4.010	GG104.TM05.080.12.40.R	M5/M6	0,80-1,00	4.00	1.70	0.60	3.70	0.50	12.00	30.00	4.00
4.011	GG104.TM05.080.17.40.R	M5/M6	0,80-1,00	4.00	1.70	0.60	3.70	0.50	17.00	35.00	4.00
4.012	GG104.TM05.080.22.40.R	M5/M6	0,80-1,00	4.00	1.70	0.60	3.70	0.50	22.00	40.00	4.00

Article no.	25149	25151	25153	25155
Cutting direction	(L)	(L)	(L)	(L)

Code no.	Description	G	P	D min	f	a	t max	E	La	Lg	D h6
				mm	mm	mm	mm	mm	mm	mm	mm
4.001	GG104.TM02.040.04.15.L	M2/M2,5	0,40-0,45	1.55	1.95	1.40	0.25	0.25	4.00	25.00	4.00
4.002	GG104.TM02.040.07.15.L	M2/M2,5	0,40-0,45	1.55	1.95	1.40	0.25	0.25	7.00	25.00	4.00
4.003	GG104.TM02.040.12.15.L	M2/M2,5	0,40-0,45	1.55	1.95	1.40	0.25	0.25	12.00	30.00	4.00
4.004	GG104.TM03.050.04.25.L	M3	0,50	2.50	1.95	2.20	0.30	0.30	4.00	25.00	4.00
4.005	GG104.TM03.050.07.25.L	M3	0,50	2.50	1.95	2.20	0.30	0.30	7.00	25.00	4.00
4.006	GG104.TM03.050.12.25.L	M3	0,50	2.50	1.95	2.20	0.30	0.30	12.00	30.00	4.00
4.007	GG104.TM04.070.07.33.L	M4	0,70	3.30	1.95	3.00	0.40	0.40	7.00	25.00	4.00
4.008	GG104.TM04.070.12.33.L	M4	0,70	3.30	1.95	3.00	0.40	0.40	12.00	30.00	4.00
4.009	GG104.TM04.070.17.33.L	M4	0,70	3.30	1.95	3.00	0.40	0.40	17.00	35.00	4.00
4.010	GG104.TM05.080.12.40.L	M5/M6	0,80-1,00	4.00	1.70	3.70	0.60	0.50	12.00	30.00	4.00
4.011	GG104.TM05.080.17.40.L	M5/M6	0,80-1,00	4.00	1.70	3.70	0.60	0.50	17.00	35.00	4.00
4.012	GG104.TM05.080.22.40.L	M5/M6	0,80-1,00	4.00	1.70	3.70	0.60	0.50	22.00	40.00	4.00



Cutting insert for internal threading, part profile - metric fine threads

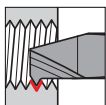

• from hole-Ø 1.7, pitch P = 0.2-0.5

for tool holders type GH104/GB104 see from page 16

Tool material

Solid carbide

Type	GG 104	GG 104	GG 104	GG 104
Surface	S TiN	a TiAlN-nanoA	C TiCN	 bright

GUHRING NAVIGATOR

Cutting data page 94

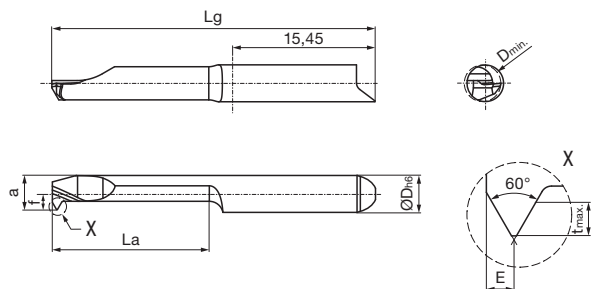

Right hand version shown
Left hand version mirror image

Article no. **25156** **25158** **25160** **25162**

Cutting direction

Code no.	Description	G	P	D min	f	t max	a	E	La	Lg	D h6
				mm	mm	mm	mm	mm	mm	mm	mm
4.001	GG104.TM02.020.04.17.R	M2/M3	0,20-0,30	1.70	1.95	0.20	1.55	0.20	4.00	25.00	4.00
4.002	GG104.TM02.020.07.17.R	M2/M3	0,20-0,30	1.70	1.95	0.20	1.55	0.20	7.00	25.00	4.00
4.003	GG104.TM02.020.12.17.R	M2/M3	0,20-0,30	1.70	1.95	0.20	1.55	0.20	12.00	30.00	4.00
4.004	GG104.TM04.035.07.35.R	M4/M5	0,35-0,50	3.50	1.95	0.30	3.20	0.35	7.00	25.00	4.00
4.005	GG104.TM04.035.12.35.R	M4/M5	0,35-0,50	3.50	1.95	0.30	3.20	0.35	12.00	30.00	4.00
4.006	GG104.TM04.035.17.35.R	M4/M5	0,35-0,50	3.50	1.95	0.30	3.20	0.35	17.00	35.00	4.00

Article no. **25157** **25159** **25161** **25163**

Cutting direction

Code no.	Description	G	P	D min	f	t max	a	E	La	Lg	D h6
				mm	mm	mm	mm	mm	mm	mm	mm
4.001	GG104.TM02.020.04.17.L	M2/M3	0,20-0,30	1.70	1.95	0.20	1.55	0.20	4.00	25.00	4.00
4.002	GG104.TM02.020.07.17.L	M2/M3	0,20-0,30	1.70	1.95	0.20	1.55	0.20	7.00	25.00	4.00
4.003	GG104.TM02.020.12.17.L	M2/M3	0,20-0,30	1.70	1.95	0.20	1.55	0.20	12.00	30.00	4.00
4.004	GG104.TM04.035.07.35.L	M4/M5	0,35-0,50	3.50	1.95	0.30	3.20	0.35	7.00	25.00	4.00
4.005	GG104.TM04.035.12.35.L	M4/M5	0,35-0,50	3.50	1.95	0.30	3.20	0.35	12.00	30.00	4.00
4.006	GG104.TM04.035.17.35.L	M4/M5	0,35-0,50	3.50	1.95	0.30	3.20	0.35	17.00	35.00	4.00



Cutting insert for internal threading, full profile - metric standard threads

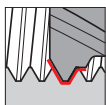

• from hole-Ø 1.5, pitch P = 0.4-0.8

Tool material	Solid carbide			
Type	GG 104	GG 104	GG 104	GG 104
Surface	S TiN	a TiAlN-nanoA	C TiCN	○ bright

for tool holders type GH104/GB104 see from page 16

GUHRING NAVIGATOR

Cutting data page 94

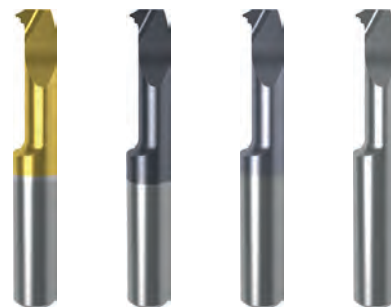
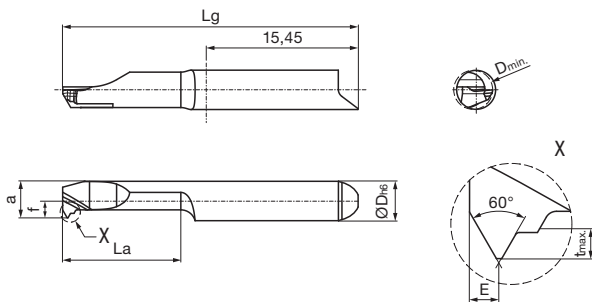

Right hand version shown
Left hand version mirror image

Article no.	25164	25166	25168	25170
Cutting direction	(R)	(R)	(R)	(R)

Code no.	Description	G	P	D min	f	t max	a	E	La	Lg	D h6
			mm	mm	mm	mm	mm	mm	mm	mm	mm
4.001	GG104.VM02.040.04.15.R	M2	0.40	1.50	1.95	0.25	1.35	0.20	4.00	25.00	4.00
4.002	GG104.VM02.040.07.15.R	M2	0.40	1.50	1.95	0.25	1.35	0.20	7.00	25.00	4.00
4.003	GG104.VM02.040.12.15.R	M2	0.40	1.50	1.95	0.25	1.35	0.20	12.00	30.00	4.00
4.004	GG104.VM03.050.04.24.R	M3	0.50	2.40	1.95	0.35	1.95	0.30	4.00	25.00	4.00
4.005	GG104.VM03.050.07.24.R	M3	0.50	2.40	1.95	0.35	1.95	0.30	7.00	25.00	4.00
4.006	GG104.VM03.050.12.24.R	M3	0.50	2.40	1.95	0.35	1.95	0.30	12.00	30.00	4.00
4.007	GG104.VM04.070.07.31.R	M4	0.70	3.10	1.95	0.45	2.80	0.40	7.00	25.00	4.00
4.008	GG104.VM04.070.12.31.R	M4	0.70	3.10	1.95	0.45	2.80	0.40	12.00	30.00	4.00
4.009	GG104.VM04.070.17.31.R	M4	0.70	3.10	1.95	0.45	2.80	0.40	17.00	35.00	4.00
4.010	GG104.VM04.070.22.31.R	M4	0.70	3.10	1.95	0.45	2.80	0.40	22.00	40.00	4.00
4.011	GG104.VM05.080.12.40.R	M5	0.80	4.00	1.70	0.50	3.70	0.50	12.00	30.00	4.00
4.012	GG104.VM05.080.17.40.R	M5	0.80	4.00	1.70	0.50	3.70	0.50	17.00	35.00	4.00
4.013	GG104.VM05.080.22.40.R	M5	0.80	4.00	1.70	0.50	3.70	0.50	22.00	40.00	4.00
4.014	GG104.VM05.080.27.40.R	M5	0.80	4.00	1.70	0.50	3.70	0.50	27.00	45.00	4.00

Article no.	25165	25167	25169	25171
Cutting direction	(L)	(L)	(L)	(L)

Code no.	Description	G	P	D min	f	t max	a	E	La	Lg	D h6
			mm	mm	mm	mm	mm	mm	mm	mm	mm
4.001	GG104.VM02.040.04.15.L	M2	0.40	1.50	1.95	0.25	1.35	0.20	4.00	25.00	4.00
4.002	GG104.VM02.040.07.15.L	M2	0.40	1.50	1.95	0.25	1.35	0.20	7.00	25.00	4.00
4.003	GG104.VM02.040.12.15.L	M2	0.40	1.50	1.95	0.25	1.35	0.20	12.00	30.00	4.00
4.004	GG104.VM03.050.04.24.L	M3	0.50	2.40	1.95	0.35	1.95	0.30	4.00	25.00	4.00
4.005	GG104.VM03.050.07.24.L	M3	0.50	2.40	1.95	0.35	1.95	0.30	7.00	25.00	4.00
4.006	GG104.VM03.050.12.24.L	M3	0.50	2.40	1.95	0.35	1.95	0.30	12.00	30.00	4.00
4.007	GG104.VM04.070.07.31.L	M4	0.70	3.10	1.95	0.45	2.80	0.40	7.00	25.00	4.00
4.008	GG104.VM04.070.12.31.L	M4	0.70	3.10	1.95	0.45	2.80	0.40	12.00	30.00	4.00
4.009	GG104.VM04.070.17.31.L	M4	0.70	3.10	1.95	0.45	2.80	0.40	17.00	35.00	4.00
4.010	GG104.VM04.070.22.31.L	M4	0.70	3.10	1.95	0.45	2.80	0.40	22.00	40.00	4.00
4.011	GG104.VM05.080.12.40.L	M5	0.80	4.00	1.70	0.50	3.70	0.50	12.00	30.00	4.00
4.012	GG104.VM05.080.17.40.L	M5	0.80	4.00	1.70	0.50	3.70	0.50	17.00	35.00	4.00
4.013	GG104.VM05.080.22.40.L	M5	0.80	4.00	1.70	0.50	3.70	0.50	22.00	40.00	4.00
4.014	GG104.VM05.080.27.40.L	M5	0.80	4.00	1.70	0.50	3.70	0.50	27.00	45.00	4.00



System 104

Cutting insert for internal threading, part profile - UN-threads

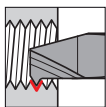

• from hole-Ø 2.6, pitch 32-40 thread/inch

for tool holders type GH104/GB104 see from page 16

Tool material	Solid carbide			
Type	GG 104	GG 104	GG 104	GG 104
Surface	S	a	C	○
	TiN	TiAlN-nanoA	TiCN	bright

GUHRING NAVIGATOR

Cutting data page 94

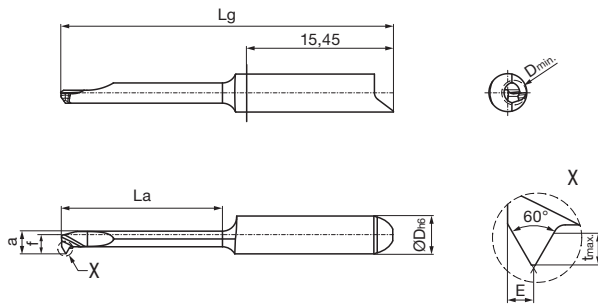

Right hand version shown
Left hand version mirror image

Article no.	25172	25174	25176	25178
Cutting direction	(R)	(R)	(R)	(R)

Code no.	Description	P	D min	f	t max	a	E	La	Lg	D h6
		G/inch	mm	mm	mm	mm	mm	mm	mm	mm
4.001	GG104.TU32.040.17.26.R	32-40	2.60	1.95	0.55	2.35	0.45	17.00	35.00	4.00

Article no.	25173	25175	25177	25179
Cutting direction	(L)	(L)	(L)	(L)

Code no.	Description	P	D min	f	t max	a	E	La	Lg	D h6
		G/inch	mm	mm	mm	mm	mm	mm	mm	mm
4.001	GG104.TU32.040.17.26.L	32-40	2.60	1.95	0.55	2.35	0.45	17.00	35.00	4.00



Cutting insert for internal threading, full profile - Whitworth pipe threads

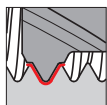

• from hole-Ø 3.3, pitch 24-80 thread/inch

for tool holders type GH104/GB104 see from page 16

GUHRING NAVIGATOR

Cutting data page 94

Tool material	Solid carbide			
Type	GG 104	GG 104	GG 104	GG 104
Surface	S	a	C	○
	TiN	TiAlN-nanoA	TiCN	bright

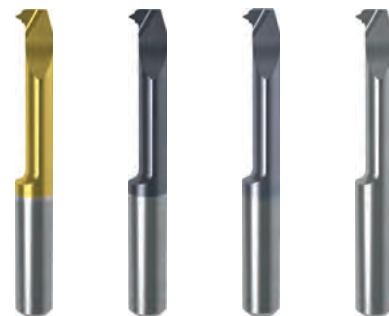
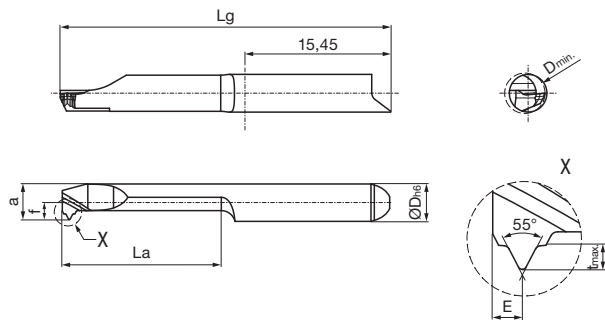

Right hand version shown
Left hand version mirror image

Article no.	25180	25182	25184	25186
Cutting direction	(R)	(R)	(R)	(R)

Code no.	Description	P	D min	f	t max	a	E	La	Lg	D h6
		G/inch	mm	mm	mm	mm	mm	mm	mm	mm
4.001	GG104.VW28.091.17.43.R	28.00	4.30	1.80	0.65	3.80	0.75	17.00	35.00	4.00
4.002	GG104.VW26.098.17.49.R	26.00	4.90	1.95	0.70	3.95	0.80	17.00	35.00	4.00
4.003	GG104.VW24.106.17.33.R	24.00	3.30	1.95	0.75	3.00	0.80	17.00	35.00	4.00

Article no.	25181	25183	25185	25187
Cutting direction	(L)	(L)	(L)	(L)

Code no.	Description	P	D min	f	t max	a	E	La	Lg	D h6
		G/inch	mm	mm	mm	mm	mm	mm	mm	mm
4.001	GG104.VW28.091.17.43.L	28.00	4.30	1.80	0.65	3.80	0.75	17.00	35.00	4.00
4.002	GG104.VW26.098.17.49.L	26.00	4.90	1.95	0.70	3.95	0.80	17.00	35.00	4.00
4.003	GG104.VW24.106.17.33.L	24.00	3.30	1.95	0.75	3.00	0.80	17.00	35.00	4.00



Round shank holder, 4 clamping surfaces

- Shank-Ø 20-25, for cutting insert type 104
- with internal coolant delivery

Type GB 104

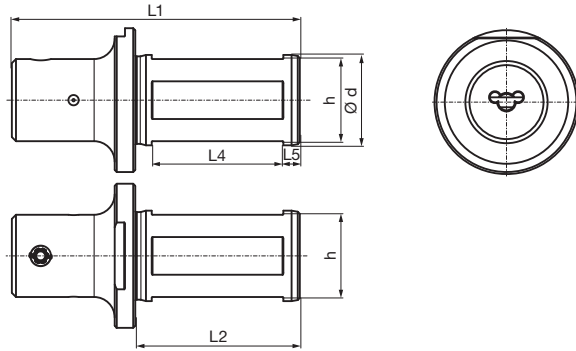

Article no. **25006**

Code no.	Description	d	h	L1	L2	L4	L5
		mm	mm	mm	mm	mm	mm
4.001	GB104.0020.070.00.15.S.IK	20.00	18.00	70.00	40.00	32.00	4.00
4.002	GB104.0022.070.00.15.S.IK	22.00	20.00	70.00	40.00	32.00	4.00
4.003	GB104.0025.070.00.15.S.IK	25.00	23.00	70.00	40.00	32.00	4.00

Spare parts

Article no.	Clamping screw	Tightening torque
25900		Nm
Code 6.000	M6x7.5x15IP	4-4.5

Article no.	Torx-Plus Wrench
25904	
Code 15.000	T15IP T-handle



Cutting insert for internal hexagon

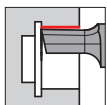

• from hole-Ø 1.5, SW 1.5-4.0

for tool holders type GB104 Art. No. 25006 see page 48

GUHRING NAVIGATOR

Cutting data page 94

Tool material	Solid carbide			
Type	GN 104	GN 104	GN 104	GN 104
Surface	S	a	C	○
	TiN	TiAlN-nanoA	TiCN	bright

System 104

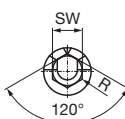
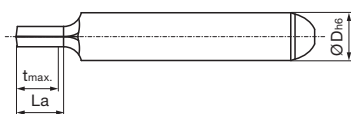
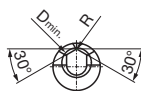
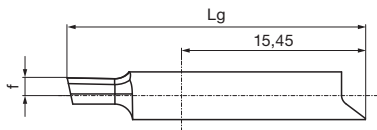

Article no. **25228** **25229** **25230** **25231**

Code no.	Description	SW	D min	R	f	t max	La	Lg	D h6
			mm	mm	mm	mm	mm	mm	mm
4.001	GN104.SW15.005.04.15.N	1,50-2,00	1.50	0.05	1.50	3.50	4.00	25.00	4.00
4.002	GN104.SW20.005.04.20.N	2,00-2,50	2.00	0.05	1.50	3.50	4.00	25.00	4.00
4.003	GN104.SW25.005.04.25.N	2,50-2,90	2.50	0.05	1.50	3.50	4.00	25.00	4.00
4.004	GN104.SW29.005.05.29.N	2,90-3,50	2.90	0.05	1.50	4.50	5.00	25.00	4.00
4.005	GN104.SW35.005.06.35.N	3,50-4,00	3.50	0.05	1.50	5.50	6.00	25.00	4.00



Cutting insert for internal square

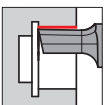

• from hole-Ø 1.5, SW 1.5-4.0

for tool holders type GB104 Art. No. 25006 see page 48

Tool material

Solid carbide

Type	GN 104	GN 104	GN 104	GN 104
Surface	S	a	C	○
	TiN	TiAlN-nanoA	TiCN	bright

GUHRING NAVIGATOR

Cutting data page 94

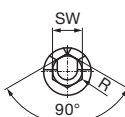
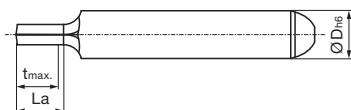
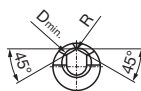
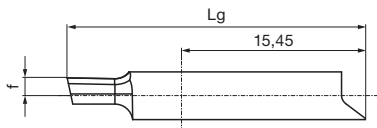

Article no. **25232** **25233** **25234** **25235**

Code no.	Description	SW	D min	R	f	t max	La	Lg	D h6
			mm	mm	mm	mm	mm	mm	mm
4.001	GN104.4545.005.04.15.N	1,50-2,00	1.50	0.05	1.50	3.50	4.00	25.00	4.00
4.002	GN104.4545.005.04.20.N	2,00-2,50	2.00	0.05	1.50	3.50	4.00	25.00	4.00
4.003	GN104.4545.005.04.25.N	2,50-2,90	2.50	0.05	1.50	3.50	4.00	25.00	4.00
4.004	GN104.4545.005.05.29.N	2,90-3,50	2.90	0.05	1.50	4.50	5.00	25.00	4.00
4.005	GN104.4545.005.06.35.N	3,50-4,00	3.50	0.05	1.50	5.50	6.00	25.00	4.00



Cutting insert for Torx

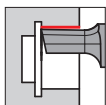

• from hole-Ø 1.75, Torx 8-30

for tool holders type GB104 Art. No. 25006 see page 48

Tool material	Solid carbide			
Type	GN 104	GN 104	GN 104	GN 104
Surface	S	a	C	○
	TiN	TiAlN-nanoA	TiCN	bright

System 104

GUHRING NAVIGATOR

Cutting data page 94

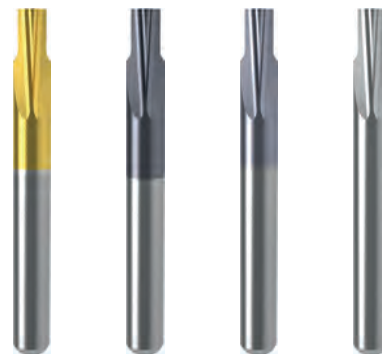
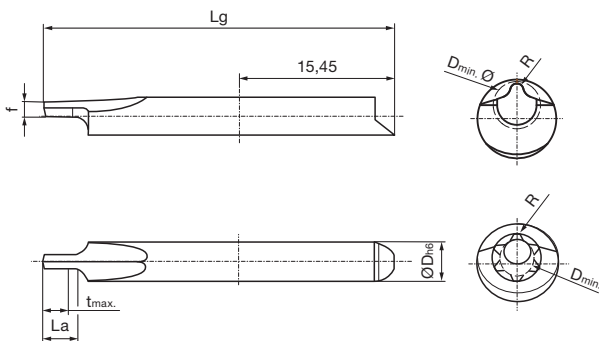

Article no. **25236** **25237** **25238** **25239**

Code no.	Description	Torx	D min	R	f	t max	La	Lg	D h6
			mm	mm	mm	mm	mm	mm	mm
4.001	GN104.TX08.024.03.17.N	T8	1.75	0.24	1.80	2.50	3.00	35.00	4.00
4.002	GN104.TX10.028.03.20.N	T10	2.05	0.28	1.80	2.50	3.00	35.00	4.00
4.003	GN104.TX15.033.04.24.N	T15	2.40	0.33	1.80	3.50	4.00	40.00	4.00
4.004	GN104.TX20.039.04.28.N	T20	2.85	0.39	1.80	3.50	4.00	40.00	4.00
4.005	GN104.TX25.045.05.32.N	T25	3.25	0.45	1.80	4.50	5.00	40.00	4.00
4.006	GN104.TX30.056.05.40.N	T30	4.05	0.56	1.80	4.50	5.00	40.00	4.00

106





SYSTEM 106

MICRO-PRECISION TOOLS



Round shank
clamping screw top
page 54



Round shank
clamping screw lateral
page 55



Round shank
Broaching
page 71

Tool holder

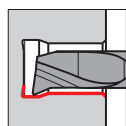

Boring out
and profiling
from page 56

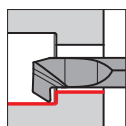

Back boring
and profiling
page 59

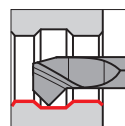

Boring out
and chamfering
page 60

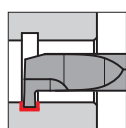

Internal grooving,
straight slots
from page 61

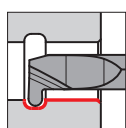

Internal grooving,
full radius slots
from page 63

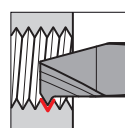

Internal threading
from page 69

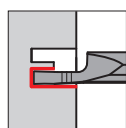

Axial grooving bores
from page 65

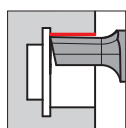

Broaching
page 72

Cutting inserts from hole- \varnothing 6 mm



Round shank holder, clamping screw top

- Shank-Ø 10-25, for cutting insert type 106
- with internal coolant delivery

Type GB 106

System 106

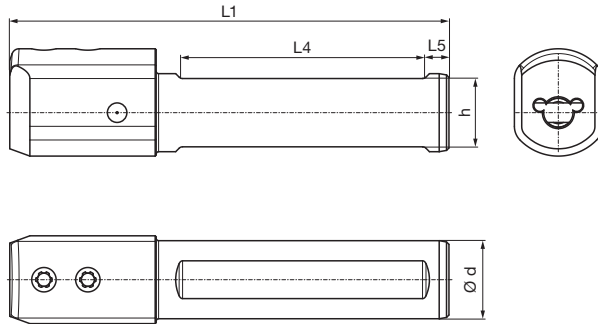

Article no. **25300**

Code no.	Description	d	h	L1	L4	L5
		mm	mm	mm	mm	mm
6.001	GB106.0010.090.00.22.N.IK	10.00	9.00	90.00	50.00	5.00
6.002	GB106.0012.090.00.22.N.IK	12.00	11.00	90.00	50.00	5.00
6.003	GB106.0016.090.00.22.N.IK	16.00	14.00	90.00	50.00	5.00
6.004	GB106.0020.095.00.22.N.IK	20.00	18.00	95.00	55.00	5.00
6.005	GB106.0022.095.00.22.N.IK	22.00	20.00	95.00	55.00	5.00
6.006	GB106.0025.100.00.22.N.IK	25.00	23.00	100.00	55.00	5.00

Spare parts

Article no.	Clamping screw	Tightening torque
25900		Nm
Code 6.000	M6x7.5x15IP	4-4.5

Article no.	Torx-Plus Wrench
25904	
Code 15.000	T15IP T-handle



Round shank holder, clamping screw lateral

- Shank-Ø 10-25, for cutting insert type 106
- with internal coolant delivery

Type GB 106

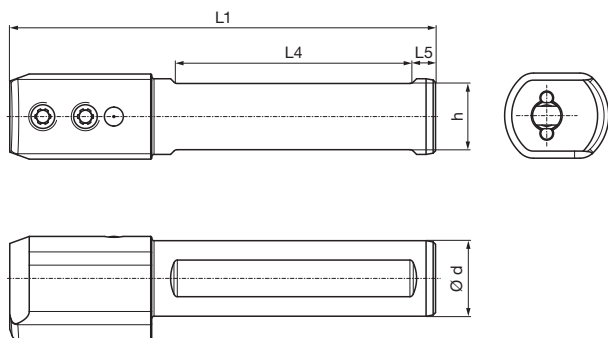

System 106

Article no. 25301

Code no.	Description	d	h	L1	L4	L5
		mm	mm	mm	mm	mm
6.001	GB106.0010.090.00.22.N.IK.90	10.00	9.00	90.00	50.00	5.00
6.002	GB106.0012.090.00.22.N.IK.90	12.00	11.00	90.00	50.00	5.00
6.003	GB106.0016.090.00.22.N.IK.90	16.00	14.00	90.00	50.00	5.00
6.004	GB106.0020.095.00.22.N.IK.90	20.00	18.00	95.00	55.00	5.00
6.005	GB106.0022.095.00.22.N.IK.90	22.00	20.00	95.00	55.00	5.00
6.006	GB106.0025.100.00.22.N.IK.90	25.00	23.00	100.00	55.00	5.00

Spare parts

Article no.	Clamping screw	Tightening torque
25900		Nm
Code 6.000	M6x7.5x15IP	4-4.5

Article no.	Torx-Plus Wrench
25904	
Code 15.000	T15IP T-handle

Cutting insert for boring out and profiling

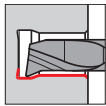

• from hole-Ø 6, radial free 23°

for tool holders type GB106 see from page 54

Tool material	Solid carbide			
	GT 106	GT 106	GT 106	GT 106
Type				
Surface	S	a	C	○
	TiN	TiAlN-nanoA	TiCN	bright

GUHRING NAVIGATOR

Cutting data page 94

System 106

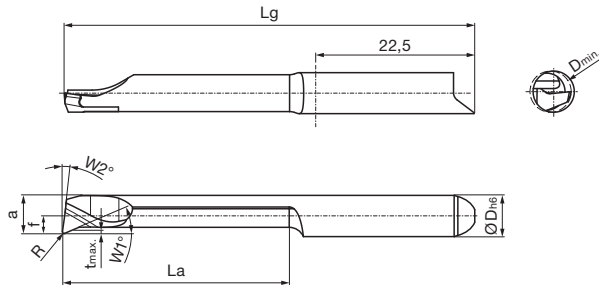

Right hand version shown
Left hand version mirror image

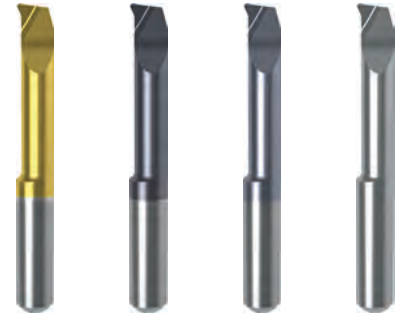

Article no.	25700	25702	25704	25706
Cutting direction	(R)	(R)	(R)	(R)

Code no.	Description	D min	R	W1	W2	f	a	t max	La	Lg	D h6
		mm	mm	°	°	mm	mm	mm	mm	mm	mm
6.001	GT106.2357.015.27.60.R	6.00	0.15	23	8	2.70	5.70	0.30	27.00	52.00	6.00
6.002	GT106.2357.015.32.60.R	6.00	0.15	23	8	2.70	5.70	0.30	32.00	57.00	6.00
6.003	GT106.2357.015.37.60.R	6.00	0.15	23	8	2.70	5.70	0.30	37.00	62.00	6.00
6.004	GT106.2357.015.42.60.R	6.00	0.15	23	8	2.70	5.70	0.30	42.00	67.00	6.00
6.005	GT106.2357.015.47.60.R	6.00	0.15	23	8	2.70	5.70	0.30	47.00	72.00	6.00
6.006	GT106.2357.015.52.60.R	6.00	0.15	23	8	2.70	5.70	0.30	52.00	77.00	6.00
6.007	GT106.2357.030.27.60.R	6.00	0.30	23	8	2.70	5.70	0.30	27.00	52.00	6.00
6.008	GT106.2357.030.32.60.R	6.00	0.30	23	8	2.70	5.70	0.30	32.00	57.00	6.00
6.009	GT106.2357.030.37.60.R	6.00	0.30	23	8	2.70	5.70	0.30	37.00	62.00	6.00
6.010	GT106.2357.030.42.60.R	6.00	0.30	23	8	2.70	5.70	0.30	42.00	67.00	6.00
6.011	GT106.2357.030.47.60.R	6.00	0.30	23	8	2.70	5.70	0.30	47.00	72.00	6.00
6.012	GT106.2357.030.52.60.R	6.00	0.30	23	8	2.70	5.70	0.30	52.00	77.00	6.00

Article no.	25701	25703	25705	25707
Cutting direction	(L)	(L)	(L)	(L)

Code no.	Description	D min	R	W1	W2	f	a	t max	La	Lg	D h6
		mm	mm	°	°	mm	mm	mm	mm	mm	mm
6.001	GT106.2357.015.27.60.L	6.00	0.15	23	8	2.70	5.70	0.30	27.00	52.00	6.00
6.002	GT106.2357.015.32.60.L	6.00	0.15	23	8	2.70	5.70	0.30	32.00	57.00	6.00
6.003	GT106.2357.015.37.60.L	6.00	0.15	23	8	2.70	5.70	0.30	37.00	62.00	6.00
6.004	GT106.2357.015.42.60.L	6.00	0.15	23	8	2.70	5.70	0.30	42.00	67.00	6.00
6.005	GT106.2357.015.47.60.L	6.00	0.15	23	8	2.70	5.70	0.30	47.00	72.00	6.00
6.006	GT106.2357.015.52.60.L	6.00	0.15	23	8	2.70	5.70	0.30	52.00	77.00	6.00
6.007	GT106.2357.030.27.60.L	6.00	0.30	23	8	2.70	5.70	0.30	27.00	52.00	6.00
6.008	GT106.2357.030.32.60.L	6.00	0.30	23	8	2.70	5.70	0.30	32.00	57.00	6.00
6.009	GT106.2357.030.37.60.L	6.00	0.30	23	8	2.70	5.70	0.30	37.00	62.00	6.00
6.010	GT106.2357.030.42.60.L	6.00	0.30	23	8	2.70	5.70	0.30	42.00	67.00	6.00
6.011	GT106.2357.030.47.60.L	6.00	0.30	23	8	2.70	5.70	0.30	47.00	72.00	6.00
6.012	GT106.2357.030.52.60.L	6.00	0.30	23	8	2.70	5.70	0.30	52.00	77.00	6.00



Cutting insert for boring out and profiling

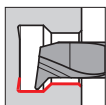

• from hole-Ø 6, radial free 47°

for tool holders type GB106 see from page 54

GUHRING NAVIGATOR

Cutting data page 94

Tool material	Solid carbide			
Type	GT 106	GT 106	GT 106	GT 106
Surface				
	TiN	TiAlN-nanoA	TiCN	bright

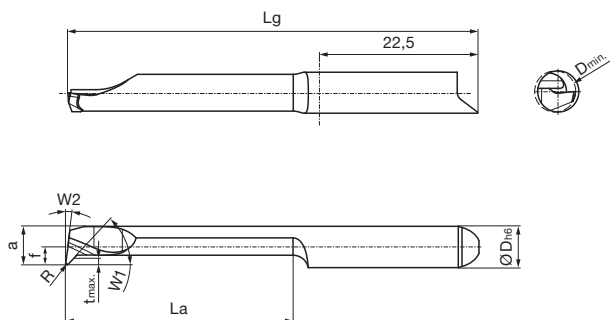

Right hand version shown
Left hand version mirror image

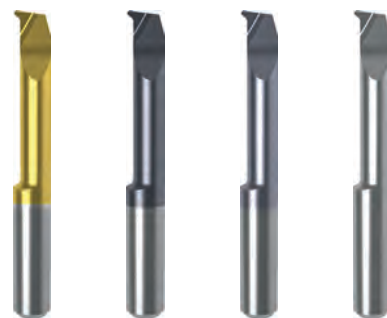

Article no.	25708	25710	25712	25714
Cutting direction				

Code no.	Description	D min	R	W1	W2	f	a	t max	La	Lg	D h6
		mm	mm	°	°	mm	mm	mm	mm	mm	mm
6.001	GT106.4757.015.27.60.R	6.00	0.15	47	8	2.70	5.70	0.60	27.00	52.00	6.00
6.002	GT106.4757.015.32.60.R	6.00	0.15	47	8	2.70	5.70	0.60	32.00	57.00	6.00
6.003	GT106.4757.015.37.60.R	6.00	0.15	47	8	2.70	5.70	0.60	37.00	62.00	6.00
6.004	GT106.4757.015.42.60.R	6.00	0.15	47	8	2.70	5.70	0.60	42.00	67.00	6.00
6.005	GT106.4757.015.47.60.R	6.00	0.15	47	8	2.70	5.70	0.60	47.00	72.00	6.00
6.006	GT106.4757.015.52.60.R	6.00	0.15	47	8	2.70	5.70	0.60	52.00	77.00	6.00
6.007	GT106.4757.030.27.60.R	6.00	0.30	47	8	2.70	5.70	0.60	27.00	52.00	6.00
6.008	GT106.4757.030.32.60.R	6.00	0.30	47	8	2.70	5.70	0.60	32.00	57.00	6.00
6.009	GT106.4757.030.37.60.R	6.00	0.30	47	8	2.70	5.70	0.60	37.00	62.00	6.00
6.010	GT106.4757.030.42.60.R	6.00	0.30	47	8	2.70	5.70	0.60	42.00	67.00	6.00
6.011	GT106.4757.030.47.60.R	6.00	0.30	47	8	2.70	5.70	0.60	47.00	72.00	6.00
6.012	GT106.4757.030.52.60.R	6.00	0.30	47	8	2.70	5.70	0.60	52.00	77.00	6.00

Article no.	25709	25711	25713	25715
Cutting direction				

Code no.	Description	D min	R	W1	W2	f	a	t max	La	Lg	D h6
		mm	mm	°	°	mm	mm	mm	mm	mm	mm
6.001	GT106.4757.015.27.60.L	6.00	0.15	47	8	2.70	5.70	0.60	27.00	52.00	6.00
6.002	GT106.4757.015.32.60.L	6.00	0.15	47	8	2.70	5.70	0.60	32.00	57.00	6.00
6.003	GT106.4757.015.37.60.L	6.00	0.15	47	8	2.70	5.70	0.60	37.00	62.00	6.00
6.004	GT106.4757.015.42.60.L	6.00	0.15	47	8	2.70	5.70	0.60	42.00	67.00	6.00
6.005	GT106.4757.015.47.60.L	6.00	0.15	47	8	2.70	5.70	0.60	47.00	72.00	6.00
6.006	GT106.4757.015.52.60.L	6.00	0.15	47	8	2.70	5.70	0.60	52.00	77.00	6.00
6.007	GT106.4757.030.27.60.L	6.00	0.30	47	8	2.70	5.70	0.60	27.00	52.00	6.00
6.008	GT106.4757.030.32.60.L	6.00	0.30	47	8	2.70	5.70	0.60	32.00	57.00	6.00
6.009	GT106.4757.030.37.60.L	6.00	0.30	47	8	2.70	5.70	0.60	37.00	62.00	6.00
6.010	GT106.4757.030.42.60.L	6.00	0.30	47	8	2.70	5.70	0.60	42.00	67.00	6.00
6.011	GT106.4757.030.47.60.L	6.00	0.30	47	8	2.70	5.70	0.60	47.00	72.00	6.00
6.012	GT106.4757.030.52.60.L	6.00	0.30	47	8	2.70	5.70	0.60	52.00	77.00	6.00

System 106

Cutting insert for boring out and profiling

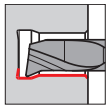

• from hole-Ø 6, VIPER-geometry

for tool holders type GB106 see from page 54

Tool material	Solid carbide			
Type	GJ 106	GJ 106	GJ 106	GJ 106
Surface	S	a	C	○
	TiN	TiAlN-nanoA	TiCN	bright

GUHRING NAVIGATOR

Cutting data page 94

System 106

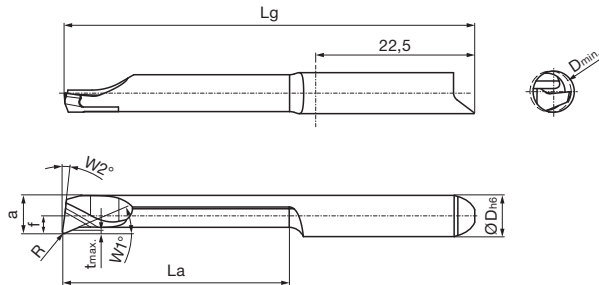

Right hand version shown
Left hand version mirror image

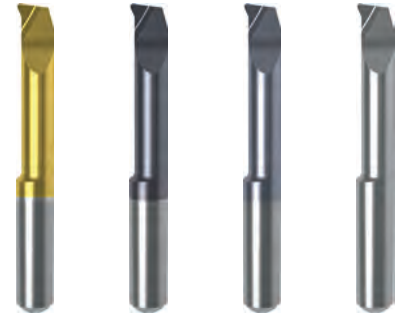

Article no.	25716	25718	25720	25722
Cutting direction	(R)	(R)	(R)	(R)

Code no.	Description	D min	R	W1	W2	f	a	t max	La	Lg	D h6
		mm	mm	°	°	mm	mm	mm	mm	mm	mm
6.001	GJ106.2357.015.27.60.R	6.00	0.15	23	8	2.70	5.70	0.30	27.00	52.00	6.00
6.002	GJ106.2357.015.32.60.R	6.00	0.15	23	8	2.70	5.70	0.30	32.00	57.00	6.00
6.003	GJ106.2357.015.37.60.R	6.00	0.15	23	8	2.70	5.70	0.30	37.00	62.00	6.00
6.004	GJ106.2357.015.42.60.R	6.00	0.15	23	8	2.70	5.70	0.30	42.00	67.00	6.00
6.005	GJ106.2357.015.47.60.R	6.00	0.15	23	8	2.70	5.70	0.30	47.00	72.00	6.00
6.006	GJ106.2357.015.52.60.R	6.00	0.15	23	8	2.70	5.70	0.30	52.00	77.00	6.00
6.007	GJ106.2357.030.27.60.R	6.00	0.30	23	8	2.70	5.70	0.30	27.00	52.00	6.00
6.008	GJ106.2357.030.32.60.R	6.00	0.30	23	8	2.70	5.70	0.30	32.00	57.00	6.00
6.009	GJ106.2357.030.37.60.R	6.00	0.30	23	8	2.70	5.70	0.30	37.00	62.00	6.00
6.010	GJ106.2357.030.42.60.R	6.00	0.30	23	8	2.70	5.70	0.30	42.00	67.00	6.00
6.011	GJ106.2357.030.47.60.R	6.00	0.30	23	8	2.70	5.70	0.30	47.00	72.00	6.00
6.012	GJ106.2357.030.52.60.R	6.00	0.30	23	8	2.70	5.70	0.30	52.00	77.00	6.00

Article no.	25717	25719	25721	25723
Cutting direction	(L)	(L)	(L)	(L)

Code no.	Description	D min	R	W1	W2	f	a	t max	La	Lg	D h6
		mm	mm	°	°	mm	mm	mm	mm	mm	mm
6.001	GJ106.2357.015.27.60.L	6.00	0.15	23	8	2.70	5.70	0.30	27.00	52.00	6.00
6.002	GJ106.2357.015.32.60.L	6.00	0.15	23	8	2.70	5.70	0.30	32.00	57.00	6.00
6.003	GJ106.2357.015.37.60.L	6.00	0.15	23	8	2.70	5.70	0.30	37.00	62.00	6.00
6.004	GJ106.2357.015.42.60.L	6.00	0.15	23	8	2.70	5.70	0.30	42.00	67.00	6.00
6.005	GJ106.2357.015.47.60.L	6.00	0.15	23	8	2.70	5.70	0.30	47.00	72.00	6.00
6.006	GJ106.2357.015.52.60.L	6.00	0.15	23	8	2.70	5.70	0.30	52.00	77.00	6.00
6.007	GJ106.2357.030.27.60.L	6.00	0.30	23	8	2.70	5.70	0.30	27.00	52.00	6.00
6.008	GJ106.2357.030.32.60.L	6.00	0.30	23	8	2.70	5.70	0.30	32.00	57.00	6.00
6.009	GJ106.2357.030.37.60.L	6.00	0.30	23	8	2.70	5.70	0.30	37.00	62.00	6.00
6.010	GJ106.2357.030.42.60.L	6.00	0.30	23	8	2.70	5.70	0.30	42.00	67.00	6.00
6.011	GJ106.2357.030.47.60.L	6.00	0.30	23	8	2.70	5.70	0.30	47.00	72.00	6.00
6.012	GJ106.2357.030.52.60.L	6.00	0.30	23	8	2.70	5.70	0.30	52.00	77.00	6.00



Cutting insert for back boring and profiling

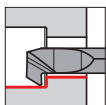

• from hole-Ø 6, radial free 32°

for tool holders type GB106 see from page 54

GUHRING NAVIGATOR

Cutting data page 94

Tool material	Solid carbide			
Type	GT 106	GT 106	GT 106	GT 106
Surface	S	a	C	○
	TiN	TiAlN-nanoA	TiCN	bright

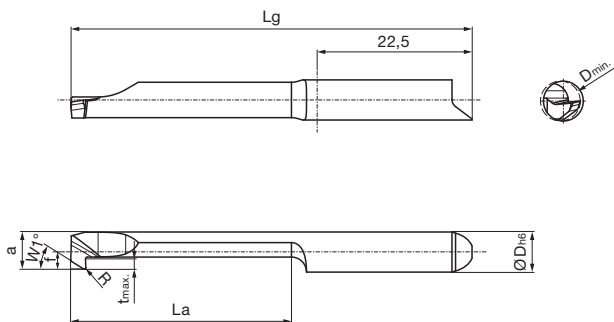

Right hand version shown
Left hand version mirror image



Article no.	25732	25734	25736	25738
Cutting direction	(R)	(R)	(R)	(R)

Code no.	Description	D min	R	W1	f	a	t max	La	Lg	D h6
		mm	mm	°	mm	mm	mm	mm	mm	mm
6.001	GT106.3257.020.22.60.R	6.00	0.20	32	2.70	5.70	2.00	22.00	47.00	6.00
6.002	GT106.3257.020.32.60.R	6.00	0.20	32	2.70	5.70	2.00	32.00	57.00	6.00
6.003	GT106.3257.020.42.60.R	6.00	0.20	32	2.70	5.70	2.00	42.00	67.00	6.00
6.004	GT106.3257.020.52.60.R	6.00	0.20	32	2.70	5.70	2.00	52.00	77.00	6.00

Article no.	25733	25735	25737	25739
Cutting direction	(L)	(L)	(L)	(L)

Code no.	Description	D min	R	W1	f	a	t max	La	Lg	D h6
		mm	mm	°	mm	mm	mm	mm	mm	mm
6.001	GT106.3257.020.22.60.L	6.00	0.20	32	2.70	5.70	2.00	22.00	47.00	6.00
6.002	GT106.3257.020.32.60.L	6.00	0.20	32	2.70	5.70	2.00	32.00	57.00	6.00
6.003	GT106.3257.020.42.60.L	6.00	0.20	32	2.70	5.70	2.00	42.00	67.00	6.00
6.004	GT106.3257.020.52.60.L	6.00	0.20	32	2.70	5.70	2.00	52.00	77.00	6.00

System 106



Cutting insert for boring out and chamfering

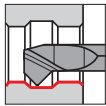

• from hole-Ø 6, 45° both sides

for tool holders type GB106 see from page 54

Tool material	Solid carbide			
Type	GT 106	GT 106	GT 106	GT 106
Surface	S	a	C	○
	TiN	TiAlN-nanoA	TiCN	bright

GUHRING NAVIGATOR

Cutting data page 94

System 106

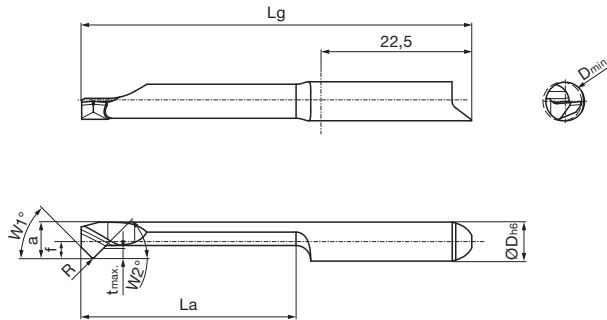

Right hand version shown
Left hand version mirror image



Article no.	25740	25742	25744	25746
Cutting direction	(R)	(R)	(R)	(R)

Code no.	Description	D min	R	W1	W2	f	a	t max	La	Lg	D h6
		mm	mm	°	°	mm	mm	mm	mm	mm	mm
6.001	GT106.4557.015.27.60.R	6.00	0.15	45	45	2.70	5.70	1.00	27.00	52.00	6.00
6.002	GT106.4557.015.32.60.R	6.00	0.15	45	45	2.70	5.70	1.00	32.00	57.00	6.00
6.003	GT106.4557.015.37.60.R	6.00	0.15	45	45	2.70	5.70	1.00	37.00	62.00	6.00
6.004	GT106.4557.015.42.60.R	6.00	0.15	45	45	2.70	5.70	1.00	42.00	67.00	6.00
6.005	GT106.4557.015.47.60.R	6.00	0.15	45	45	2.70	5.70	1.00	47.00	72.00	6.00
6.006	GT106.4557.015.52.60.R	6.00	0.15	45	45	2.70	5.70	1.00	52.00	77.00	6.00
6.007	GT106.4557.030.27.60.R	6.00	0.30	45	45	2.70	5.70	1.00	27.00	52.00	6.00
6.008	GT106.4557.030.32.60.R	6.00	0.30	45	45	2.70	5.70	1.00	32.00	57.00	6.00
6.009	GT106.4557.030.37.60.R	6.00	0.30	45	45	2.70	5.70	1.00	37.00	62.00	6.00
6.010	GT106.4557.030.42.60.R	6.00	0.30	45	45	2.70	5.70	1.00	42.00	67.00	6.00
6.011	GT106.4557.030.47.60.R	6.00	0.30	45	45	2.70	5.70	1.00	47.00	72.00	6.00
6.012	GT106.4557.030.52.60.R	6.00	0.30	45	45	2.70	5.70	1.00	52.00	77.00	6.00

Article no.	25741	25743	25745	25747
Cutting direction	(L)	(L)	(L)	(L)

Code no.	Description	D min	R	W1	W2	f	a	t max	La	Lg	D h6
		mm	mm	°	°	mm	mm	mm	mm	mm	mm
6.001	GT106.4557.015.27.60.L	6.00	0.15	45	45	2.70	5.70	1.00	27.00	52.00	6.00
6.002	GT106.4557.015.32.60.L	6.00	0.15	45	45	2.70	5.70	1.00	32.00	57.00	6.00
6.003	GT106.4557.015.37.60.L	6.00	0.15	45	45	2.70	5.70	1.00	37.00	62.00	6.00
6.004	GT106.4557.015.42.60.L	6.00	0.15	45	45	2.70	5.70	1.00	42.00	67.00	6.00
6.005	GT106.4557.015.47.60.L	6.00	0.15	45	45	2.70	5.70	1.00	47.00	72.00	6.00
6.006	GT106.4557.015.52.60.L	6.00	0.15	45	45	2.70	5.70	1.00	52.00	77.00	6.00
6.007	GT106.4557.030.27.60.L	6.00	0.30	45	45	2.70	5.70	1.00	27.00	52.00	6.00
6.008	GT106.4557.030.32.60.L	6.00	0.30	45	45	2.70	5.70	1.00	32.00	57.00	6.00
6.009	GT106.4557.030.37.60.L	6.00	0.30	45	45	2.70	5.70	1.00	37.00	62.00	6.00
6.010	GT106.4557.030.42.60.L	6.00	0.30	45	45	2.70	5.70	1.00	42.00	67.00	6.00
6.011	GT106.4557.030.47.60.L	6.00	0.30	45	45	2.70	5.70	1.00	47.00	72.00	6.00
6.012	GT106.4557.030.52.60.L	6.00	0.30	45	45	2.70	5.70	1.00	52.00	77.00	6.00



Cutting insert for internal grooving, straight slots

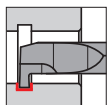

• from hole-Ø 6, grooving depth up to 2 mm

for tool holders type GB106 see from page 54

GUHRING NAVIGATOR

Cutting data page 94

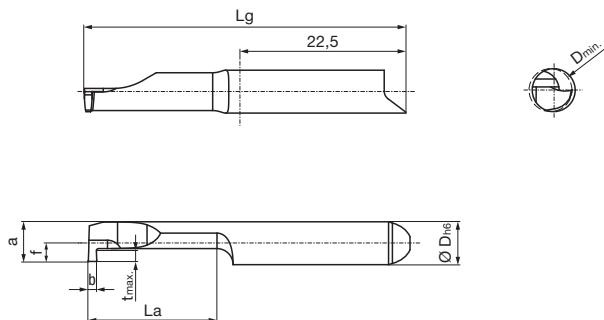

Right hand version shown
Left hand version mirror image

Tool material	Solid carbide			
Type	GE 106	GE 106	GE 106	GE 106
Surface	S	a	C	○
	TiN	TiAlN-nanoA	TiCN	bright



Article no.	25748	25750	25752	25754
Cutting direction	(R)	(R)	(R)	(R)

Code no.	Description	D min	b	f	a	t max	La	Lg	D h6
		mm	mm	mm	mm	mm	mm	mm	mm
6.001	GE106.0100.000.12.60.R	6.00	1.00	2.70	5.70	2.00	12.00	37.00	6.00
6.002	GE106.0100.000.17.60.R	6.00	1.00	2.70	5.70	2.00	17.00	42.00	6.00
6.003	GE106.0100.000.22.60.R	6.00	1.00	2.70	5.70	2.00	22.00	47.00	6.00
6.004	GE106.0100.000.27.60.R	6.00	1.00	2.70	5.70	2.00	27.00	52.00	6.00
6.005	GE106.0100.000.32.60.R	6.00	1.00	2.70	5.70	2.00	32.00	57.00	6.00
6.006	GE106.0100.000.37.60.R	6.00	1.00	2.70	5.70	2.00	37.00	62.00	6.00
6.007	GE106.0100.000.42.60.R	6.00	1.00	2.70	5.70	2.00	42.00	67.00	6.00
6.008	GE106.0150.000.12.60.R	6.00	1.50	2.70	5.70	2.00	12.00	37.00	6.00
6.009	GE106.0150.000.17.60.R	6.00	1.50	2.70	5.70	2.00	17.00	42.00	6.00
6.010	GE106.0150.000.22.60.R	6.00	1.50	2.70	5.70	2.00	22.00	47.00	6.00
6.011	GE106.0150.000.27.60.R	6.00	1.50	2.70	5.70	2.00	27.00	52.00	6.00
6.012	GE106.0150.000.32.60.R	6.00	1.50	2.70	5.70	2.00	32.00	57.00	6.00
6.013	GE106.0150.000.37.60.R	6.00	1.50	2.70	5.70	2.00	37.00	62.00	6.00
6.014	GE106.0150.000.42.60.R	6.00	1.50	2.70	5.70	2.00	42.00	67.00	6.00
6.015	GE106.0200.000.12.60.R	6.00	2.00	2.70	5.70	2.00	12.00	37.00	6.00
6.016	GE106.0200.000.17.60.R	6.00	2.00	2.70	5.70	2.00	17.00	42.00	6.00
6.017	GE106.0200.000.22.60.R	6.00	2.00	2.70	5.70	2.00	22.00	47.00	6.00
6.018	GE106.0200.000.27.60.R	6.00	2.00	2.70	5.70	2.00	27.00	52.00	6.00
6.019	GE106.0200.000.32.60.R	6.00	2.00	2.70	5.70	2.00	32.00	57.00	6.00
6.020	GE106.0200.000.37.60.R	6.00	2.00	2.70	5.70	2.00	37.00	62.00	6.00
6.021	GE106.0200.000.42.60.R	6.00	2.00	2.70	5.70	2.00	42.00	67.00	6.00

Article no.	25749	25751	25753	25755
Cutting direction	(L)	(L)	(L)	(L)

Code no.	Description	D min	b	f	a	t max	La	Lg	D h6
		mm	mm	mm	mm	mm	mm	mm	mm
6.001	GE106.0100.000.12.60.L	6.00	1.00	2.70	5.70	2.00	12.00	37.00	6.00
6.002	GE106.0100.000.17.60.L	6.00	1.00	2.70	5.70	2.00	17.00	42.00	6.00
6.003	GE106.0100.000.22.60.L	6.00	1.00	2.70	5.70	2.00	22.00	47.00	6.00
6.004	GE106.0100.000.27.60.L	6.00	1.00	2.70	5.70	2.00	27.00	52.00	6.00
6.005	GE106.0100.000.32.60.L	6.00	1.00	2.70	5.70	2.00	32.00	57.00	6.00
6.006	GE106.0100.000.37.60.L	6.00	1.00	2.70	5.70	2.00	37.00	62.00	6.00



Article no. **25749** **25751** **25753** **25755**

Cutting direction    

System 106

Code no.	Description	D min	b	f	a	t max	La	Lg	D h6
		mm	mm	mm	mm	mm	mm	mm	mm
6.007	GE106.0100.000.42.60.L	6.00	1.00	2.70	5.70	2.00	42.00	67.00	6.00
6.008	GE106.0150.000.12.60.L	6.00	1.50	2.70	5.70	2.00	12.00	37.00	6.00
6.009	GE106.0150.000.17.60.L	6.00	1.50	2.70	5.70	2.00	17.00	42.00	6.00
6.010	GE106.0150.000.22.60.L	6.00	1.50	2.70	5.70	2.00	22.00	47.00	6.00
6.011	GE106.0150.000.27.60.L	6.00	1.50	2.70	5.70	2.00	27.00	52.00	6.00
6.012	GE106.0150.000.32.60.L	6.00	1.50	2.70	5.70	2.00	32.00	57.00	6.00
6.013	GE106.0150.000.37.60.L	6.00	1.50	2.70	5.70	2.00	37.00	62.00	6.00
6.014	GE106.0150.000.42.60.L	6.00	1.50	2.70	5.70	2.00	42.00	67.00	6.00
6.015	GE106.0200.000.12.60.L	6.00	2.00	2.70	5.70	2.00	12.00	37.00	6.00
6.016	GE106.0200.000.17.60.L	6.00	2.00	2.70	5.70	2.00	17.00	42.00	6.00
6.017	GE106.0200.000.22.60.L	6.00	2.00	2.70	5.70	2.00	22.00	47.00	6.00
6.018	GE106.0200.000.27.60.L	6.00	2.00	2.70	5.70	2.00	27.00	52.00	6.00
6.019	GE106.0200.000.32.60.L	6.00	2.00	2.70	5.70	2.00	32.00	57.00	6.00
6.020	GE106.0200.000.37.60.L	6.00	2.00	2.70	5.70	2.00	37.00	62.00	6.00
6.021	GE106.0200.000.42.60.L	6.00	2.00	2.70	5.70	2.00	42.00	67.00	6.00



Cutting insert for internal grooving, full radius slots

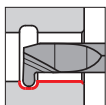

• from hole-Ø 6, full radius R0.5-R1.0

for tool holders type GB106 see from page 54

GUHRING NAVIGATOR

Cutting data page 94

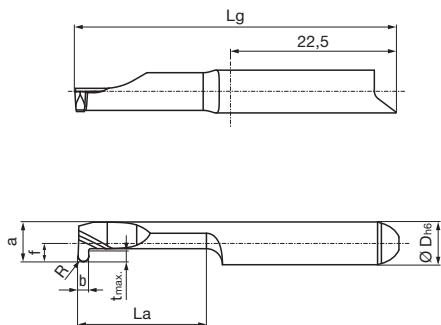

Right hand version shown
Left hand version mirror image

Article no.	25756	25758	25760	25762
Cutting direction				

Code no.	Description	D min	b	R	f	a	t max	La	Lg	D h6
		mm	mm	mm	mm	mm	mm	mm	mm	mm
6.001	GE106.0100.050.12.60.R	6.00	1.00	0.50	2.70	5.70	2.00	12.00	37.00	6.00
6.002	GE106.0100.050.17.60.R	6.00	1.00	0.50	2.70	5.70	2.00	17.00	42.00	6.00
6.003	GE106.0100.050.22.60.R	6.00	1.00	0.50	2.70	5.70	2.00	22.00	47.00	6.00
6.004	GE106.0100.050.27.60.R	6.00	1.00	0.50	2.70	5.70	2.00	27.00	52.00	6.00
6.005	GE106.0100.050.32.60.R	6.00	1.00	0.50	2.70	5.70	2.00	32.00	57.00	6.00
6.006	GE106.0100.050.37.60.R	6.00	1.00	0.50	2.70	5.70	2.00	37.00	62.00	6.00
6.007	GE106.0100.050.42.60.R	6.00	1.00	0.50	2.70	5.70	2.00	42.00	67.00	6.00
6.008	GE106.0150.075.12.60.R	6.00	1.50	0.75	2.70	5.70	2.00	12.00	37.00	6.00
6.009	GE106.0150.075.17.60.R	6.00	1.50	0.75	2.70	5.70	2.00	17.00	42.00	6.00
6.010	GE106.0150.075.22.60.R	6.00	1.50	0.75	2.70	5.70	2.00	22.00	47.00	6.00
6.011	GE106.0150.075.27.60.R	6.00	1.50	0.75	2.70	5.70	2.00	27.00	52.00	6.00
6.012	GE106.0150.075.32.60.R	6.00	1.50	0.75	2.70	5.70	2.00	32.00	57.00	6.00
6.013	GE106.0150.075.37.60.R	6.00	1.50	0.75	2.70	5.70	2.00	37.00	62.00	6.00
6.014	GE106.0150.075.42.60.R	6.00	1.50	0.75	2.70	5.70	2.00	42.00	67.00	6.00
6.015	GE106.0200.100.12.60.R	6.00	2.00	1.00	2.70	5.70	2.00	12.00	37.00	6.00
6.016	GE106.0200.100.17.60.R	6.00	2.00	1.00	2.70	5.70	2.00	17.00	42.00	6.00
6.017	GE106.0200.100.22.60.R	6.00	2.00	1.00	2.70	5.70	2.00	22.00	47.00	6.00
6.018	GE106.0200.100.27.60.R	6.00	2.00	1.00	2.70	5.70	2.00	27.00	52.00	6.00
6.019	GE106.0200.100.32.60.R	6.00	2.00	1.00	2.70	5.70	2.00	32.00	57.00	6.00
6.020	GE106.0200.100.37.60.R	6.00	2.00	1.00	2.70	5.70	2.00	37.00	62.00	6.00
6.021	GE106.0200.100.42.60.R	6.00	2.00	1.00	2.70	5.70	2.00	42.00	67.00	6.00

Article no.	25757	25759	25761	25763
Cutting direction				

Code no.	Description	D min	b	R	f	a	t max	La	Lg	D h6
		mm	mm	mm	mm	mm	mm	mm	mm	mm
6.001	GE106.0100.050.12.60.L	6.00	1.00	0.50	2.70	5.70	2.00	12.00	37.00	6.00
6.002	GE106.0100.050.17.60.L	6.00	1.00	0.50	2.70	5.70	2.00	17.00	42.00	6.00
6.003	GE106.0100.050.22.60.L	6.00	1.00	0.50	2.70	5.70	2.00	22.00	47.00	6.00
6.004	GE106.0100.050.27.60.L	6.00	1.00	0.50	2.70	5.70	2.00	27.00	52.00	6.00
6.005	GE106.0100.050.32.60.L	6.00	1.00	0.50	2.70	5.70	2.00	32.00	57.00	6.00
6.006	GE106.0100.050.37.60.L	6.00	1.00	0.50	2.70	5.70	2.00	37.00	62.00	6.00

System 106



Article no. **25757** **25759** **25761** **25763**

Cutting direction    

System 106

Code no.	Description	D min	b	R	f	a	t max	La	Lg	D h6
		mm	mm	mm	mm	mm	mm	mm	mm	mm
6.007	GE106.0100.050.42.60.L	6.00	1.00	0.50	2.70	5.70	2.00	42.00	67.00	6.00
6.008	GE106.0150.075.12.60.L	6.00	1.50	0.75	2.70	5.70	2.00	12.00	37.00	6.00
6.009	GE106.0150.075.17.60.L	6.00	1.50	0.75	2.70	5.70	2.00	17.00	42.00	6.00
6.010	GE106.0150.075.22.60.L	6.00	1.50	0.75	2.70	5.70	2.00	22.00	47.00	6.00
6.011	GE106.0150.075.27.60.L	6.00	1.50	0.75	2.70	5.70	2.00	27.00	52.00	6.00
6.012	GE106.0150.075.32.60.L	6.00	1.50	0.75	2.70	5.70	2.00	32.00	57.00	6.00
6.013	GE106.0150.075.37.60.L	6.00	1.50	0.75	2.70	5.70	2.00	37.00	62.00	6.00
6.014	GE106.0150.075.42.60.L	6.00	1.50	0.75	2.70	5.70	2.00	42.00	67.00	6.00
6.015	GE106.0200.100.12.60.L	6.00	2.00	1.00	2.70	5.70	2.00	12.00	37.00	6.00
6.016	GE106.0200.100.17.60.L	6.00	2.00	1.00	2.70	5.70	2.00	17.00	42.00	6.00
6.017	GE106.0200.100.22.60.L	6.00	2.00	1.00	2.70	5.70	2.00	22.00	47.00	6.00
6.018	GE106.0200.100.27.60.L	6.00	2.00	1.00	2.70	5.70	2.00	27.00	52.00	6.00
6.019	GE106.0200.100.32.60.L	6.00	2.00	1.00	2.70	5.70	2.00	32.00	57.00	6.00
6.020	GE106.0200.100.37.60.L	6.00	2.00	1.00	2.70	5.70	2.00	37.00	62.00	6.00
6.021	GE106.0200.100.42.60.L	6.00	2.00	1.00	2.70	5.70	2.00	42.00	67.00	6.00



Cutting insert for axial grooving bores, straight slots

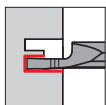

• from hole-Ø 6, grooving depth up to 8 mm

for tool holders type GB106 see from page 54

GUHRING NAVIGATOR

Cutting data page 94

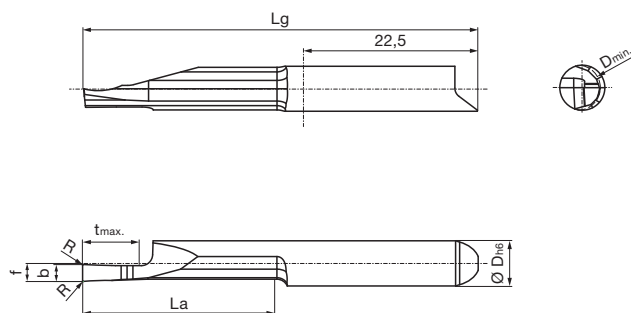

Right hand version shown
Left hand version mirror image

Tool material	Solid carbide			
Type	GA 106	GA 106	GA 106	GA 106
Surface	S	a	C	○
	TiN	TiAlN-nanoA	TiCN	bright



Article no.	25780	25782	25784	25786
Cutting direction	(R)	(R)	(R)	(R)

Code no.	Description	D min	b	R	f	t max	La	Lg	D h6
		mm	mm	mm	mm	mm	mm	mm	mm
6.001	GA106.0150.010.17.60.R	6.00	1.50	0.10	2.60	5.00	17.00	42.00	6.00
6.002	GA106.0150.010.22.60.R	6.00	1.50	0.10	2.60	5.00	22.00	47.00	6.00
6.003	GA106.0200.015.17.60.R	6.00	2.00	0.15	2.60	8.00	17.00	42.00	6.00
6.004	GA106.0200.015.22.60.R	6.00	2.00	0.15	2.60	8.00	22.00	47.00	6.00

Article no.	25781	25783	25785	25787
Cutting direction	(L)	(L)	(L)	(L)

Code no.	Description	D min	b	R	f	t max	La	Lg	D h6
		mm	mm	mm	mm	mm	mm	mm	mm
6.001	GA106.0150.010.17.60.L	6.00	1.50	0.10	2.60	5.00	17.00	42.00	6.00
6.002	GA106.0150.010.22.60.L	6.00	1.50	0.10	2.60	5.00	22.00	47.00	6.00
6.003	GA106.0200.015.17.60.L	6.00	2.00	0.15	2.60	8.00	17.00	42.00	6.00
6.004	GA106.0200.015.22.60.L	6.00	2.00	0.15	2.60	8.00	22.00	47.00	6.00

System 106



Cutting insert for axial grooving bores, full radius slots



• from hole-Ø 6, grooving depth up to 8 mm

for tool holders type GB106 see from page 54

Tool material	Solid carbide			
Type	GA 106	GA 106	GA 106	GA 106
Surface	S	a	C	○
	TiN	TiAlN-nanoA	TiCN	bright

System 106

GUHRING NAVIGATOR

Cutting data page 94

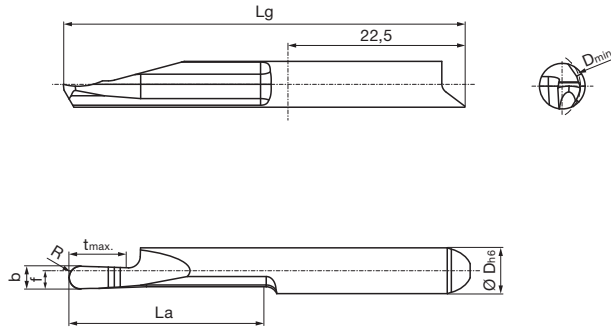

Right hand version shown
Left hand version mirror image



Article no.	25788	25790	25792	25794
Cutting direction	(R)	(R)	(R)	(R)

Code no.	Description	D min	b	R	f	t max	La	Lg	D h6
		mm	mm	mm	mm	mm	mm	mm	mm
6.001	GA106.0150.075.17.60.R	6.00	1.50	0.75	2.60	5.00	17.00	42.00	6.00
6.002	GA106.0150.075.22.60.R	6.00	1.50	0.75	2.60	5.00	22.00	47.00	6.00
6.003	GA106.0200.100.17.60.R	6.00	2.00	1.00	2.60	8.00	17.00	42.00	6.00
6.004	GA106.0200.100.22.60.R	6.00	2.00	1.00	2.60	8.00	22.00	47.00	6.00

Article no.	25789	25791	25793	25795
Cutting direction	(L)	(L)	(L)	(L)

Code no.	Description	D min	b	R	f	t max	La	Lg	D h6
		mm	mm	mm	mm	mm	mm	mm	mm
6.001	GA106.0150.075.17.60.L	6.00	1.50	0.75	2.60	5.00	17.00	42.00	6.00
6.002	GA106.0150.075.22.60.L	6.00	1.50	0.75	2.60	5.00	22.00	47.00	6.00
6.003	GA106.0200.100.17.60.L	6.00	2.00	1.00	2.60	8.00	17.00	42.00	6.00
6.004	GA106.0200.100.22.60.L	6.00	2.00	1.00	2.60	8.00	22.00	47.00	6.00



Cutting insert for axial grooving studs, straight slots

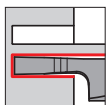

• from hole-Ø 6, grooving depth up to 8 mm

for tool holders type GB106 see from page 54

GUHRING NAVIGATOR

Cutting data page 94

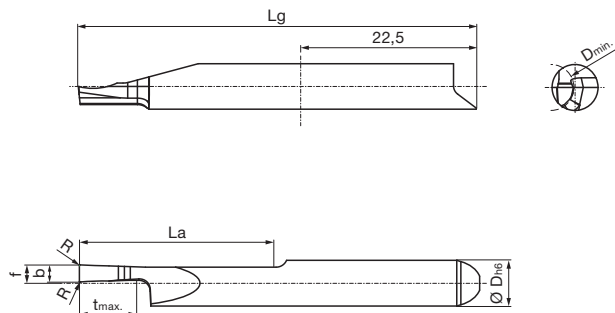

Right hand version shown
Left hand version mirror image



Tool material	Solid carbide			
Type	GA 106	GA 106	GA 106	GA 106
Surface				
	TiN	TiAlN-nanoA	TiCN	bright

System 106

Article no.	25796	25798	25800	25802
Cutting direction				

Code no.	Description	D min	b	R	f	t max	La	Lg	D h6
		mm	mm	mm	mm	mm	mm	mm	mm
6.001	GA106.Z150.010.17.60.R	6.00	1.50	0.10	2.60	5.00	17.00	42.00	6.00
6.002	GA106.Z150.010.22.60.R	6.00	1.50	0.10	2.60	5.00	22.00	47.00	6.00
6.003	GA106.Z200.015.17.60.R	6.00	2.00	0.15	2.60	8.00	17.00	42.00	6.00
6.004	GA106.Z200.015.22.60.R	6.00	2.00	0.15	2.60	8.00	22.00	47.00	6.00

Article no.	25797	25799	25801	25803
Cutting direction				

Code no.	Description	D min	b	R	f	t max	La	Lg	D h6
		mm	mm	mm	mm	mm	mm	mm	mm
6.001	GA106.Z150.010.17.60.L	6.00	1.50	0.10	2.60	5.00	17.00	42.00	6.00
6.002	GA106.Z150.010.22.60.L	6.00	1.50	0.10	2.60	5.00	22.00	47.00	6.00
6.003	GA106.Z200.015.17.60.L	6.00	2.00	0.15	2.60	8.00	17.00	42.00	6.00
6.004	GA106.Z200.015.22.60.L	6.00	2.00	0.15	2.60	8.00	22.00	47.00	6.00



Cutting insert for axial grooving studs, full radius slots



• from hole-Ø 6, grooving depth up to 8 mm

for tool holders type GB106 see from page 54

Tool material

Solid carbide

Type	GA 106	GA 106	GA 106	GA 106
Surface				
	TiN	TiAlN-nanoA	TiCN	bright

GUHRING NAVIGATOR

Cutting data page 94

System 106

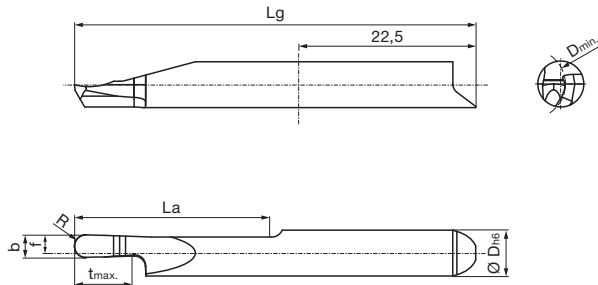

Right hand version shown
Left hand version mirror image

Article no. **25804** **25806** **25808** **25810**

Cutting direction

Code no.	Description	D min	b	R	f	t max	La	Lg	D h6
		mm	mm	mm	mm	mm	mm	mm	mm
6.001	GA106.Z150.075.17.60.R	6.00	1.50	0.75	2.60	5.00	17.00	42.00	6.00
6.002	GA106.Z150.075.22.60.R	6.00	1.50	0.75	2.60	5.00	22.00	47.00	6.00
6.003	GA106.Z200.100.17.60.R	6.00	2.00	1.00	2.60	8.00	17.00	42.00	6.00
6.004	GA106.Z200.100.22.60.R	6.00	2.00	1.00	2.60	8.00	22.00	47.00	6.00

Article no. **25805** **25807** **25809** **25811**

Cutting direction

Code no.	Description	D min	b	R	f	t max	La	Lg	D h6
		mm	mm	mm	mm	mm	mm	mm	mm
6.001	GA106.Z150.075.17.60.L	6.00	1.50	0.75	2.60	5.00	17.00	42.00	6.00
6.002	GA106.Z150.075.22.60.L	6.00	1.50	0.75	2.60	5.00	22.00	47.00	6.00
6.003	GA106.Z200.100.17.60.L	6.00	2.00	1.00	2.60	8.00	17.00	42.00	6.00
6.004	GA106.Z200.100.22.60.L	6.00	2.00	1.00	2.60	8.00	22.00	47.00	6.00



Cutting insert for internal threading, part profile - metric standard threads

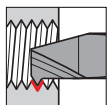

• from hole-Ø 6.8, pitch P = 1.25-1.75

for tool holders type GB106 see from page 54

GUHRING NAVIGATOR

Cutting data page 94

Tool material	Solid carbide			
	GG 106	GG 106	GG 106	GG 106
Type	GG 106	GG 106	GG 106	GG 106
Surface	S TiN	a TiAlN-nanoA	C TiCN	O bright

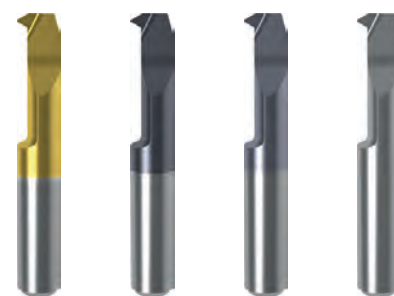
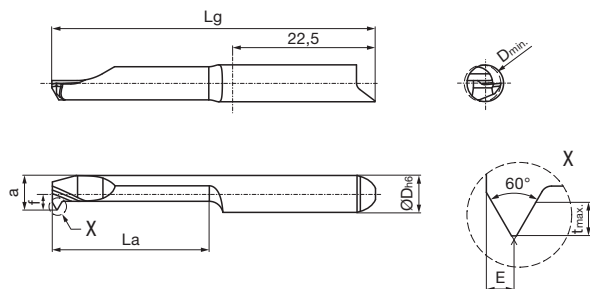

Right hand version shown
Left hand version mirror image

Article no.	25764	25766	25768	25770
Cutting direction	R	R	R	R

Code no.	Description	G	P	D min	f	E	a	t max	La	Lg	D h6
			mm	mm	mm	mm	mm	mm	mm	mm	mm
6.001	GG106.TM08.125.17.68.R	M8	1.25	6.80	2.95	0.70	5.95	0.70	17.00	42.00	6.00
6.002	GG106.TM08.125.22.68.R	M8	1.25	6.80	2.95	0.70	5.95	0.70	22.00	47.00	6.00
6.003	GG106.TM08.125.27.68.R	M8	1.25	6.80	2.95	0.70	5.95	0.70	27.00	52.00	6.00
6.004	GG106.TM10.150.17.85.R	M10	1.50	8.50	2.95	0.85	5.95	0.85	17.00	42.00	6.00
6.005	GG106.TM10.150.22.85.R	M10	1.50	8.50	2.95	0.85	5.95	0.85	22.00	47.00	6.00
6.006	GG106.TM10.150.27.85.R	M10	1.50	8.50	2.95	0.85	5.95	0.85	27.00	52.00	6.00
6.007	GG106.TM12.175.17.99.R	M12	1.75	10.20	2.95	1.00	5.95	1.00	17.00	42.00	6.00
6.008	GG106.TM12.175.22.99.R	M12	1.75	10.20	2.95	1.00	5.95	1.00	22.00	47.00	6.00
6.009	GG106.TM12.175.27.99.R	M12	1.75	10.20	2.95	1.00	5.95	1.00	27.00	52.00	6.00

Article no.	25765	25767	25769	25771
Cutting direction	L	L	L	L

Code no.	Description	G	P	D min	f	E	a	t max	La	Lg	D h6
			mm	mm	mm	mm	mm	mm	mm	mm	mm
6.001	GG106.TM08.125.17.68.L	M8	1.25	6.80	2.95	0.70	5.95	0.70	17.00	42.00	6.00
6.002	GG106.TM08.125.22.68.L	M8	1.25	6.80	2.95	0.70	5.95	0.70	22.00	47.00	6.00
6.003	GG106.TM08.125.27.68.L	M8	1.25	6.80	2.95	0.70	5.95	0.70	27.00	52.00	6.00
6.004	GG106.TM10.150.17.85.L	M10	1.50	8.50	2.95	0.85	5.95	0.85	17.00	42.00	6.00
6.005	GG106.TM10.150.22.85.L	M10	1.50	8.50	2.95	0.85	5.95	0.85	22.00	47.00	6.00
6.006	GG106.TM10.150.27.85.L	M10	1.50	8.50	2.95	0.85	5.95	0.85	27.00	52.00	6.00
6.007	GG106.TM12.175.17.99.L	M12	1.75	10.20	2.95	1.00	5.95	1.00	17.00	42.00	6.00
6.008	GG106.TM12.175.22.99.L	M12	1.75	10.20	2.95	1.00	5.95	1.00	22.00	47.00	6.00
6.009	GG106.TM12.175.27.99.L	M12	1.75	10.20	2.95	1.00	5.95	1.00	27.00	52.00	6.00

System 106



Cutting insert for internal threading, part profile - trapezoidal thread

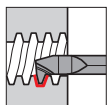

• from hole-Ø 6,5, pitch P = 1.5-3.0

for tool holders type GB106 see from page 54

Tool material

Solid carbide

Type	GG 106	GG 106	GG 106	GG 106
Surface	S TiN	a TiAlN-nanoA	C TiCN	 bright

GUHRING NAVIGATOR

Cutting data page 94

System 106

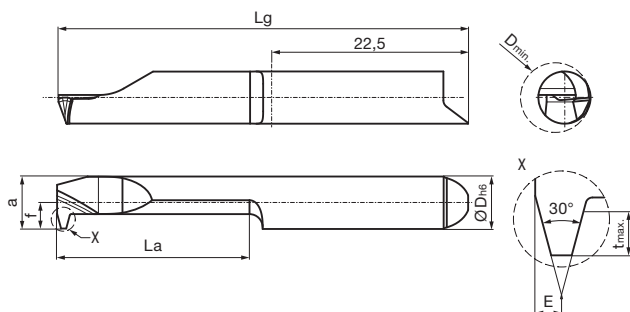

Right hand version shown
Left hand version mirror image

Article no. **25824** **25826** **25828** **25830**

Cutting direction

Code no.	Description	G	P	D min	f	E	a	t max	La	Lg	D h6
			mm	mm	mm	mm	mm	mm	mm	mm	mm
6.001	GG106.TT08.150.22.65.R	Tr8	1.50	6.50	2.95	0.60	5.95	0.90	22.00	47.00	6.00
6.002	GG106.TT08.200.22.60.R	Tr8	2.00	6.00	2.70	0.75	5.70	1.25	22.00	47.00	6.00
6.003	GG106.TT10.200.22.80.R	Tr10	2.00	8.00	2.95	0.75	5.95	1.25	22.00	47.00	6.00
6.004	GG106.TT10.200.32.80.R	Tr10	2.00	8.00	2.95	0.75	5.95	1.25	32.00	57.00	6.00
6.005	GG106.TT10.300.22.70.R	Tr10	3.00	7.00	2.95	1.10	5.95	1.75	22.00	47.00	6.00
6.006	GG106.TT10.300.32.70.R	Tr10	3.00	7.00	2.95	1.10	5.95	1.75	32.00	57.00	6.00

Article no. **25825** **25827** **25829** **25831**

Cutting direction

Code no.	Description	G	P	D min	f	E	a	t max	La	Lg	D h6
			mm	mm	mm	mm	mm	mm	mm	mm	mm
6.001	GG106.TT08.150.22.65.L	Tr8	1.50	6.50	2.95	0.60	5.95	0.90	22.00	47.00	6.00
6.002	GG106.TT08.200.22.60.L	Tr8	2.00	6.00	2.70	0.75	5.70	1.25	22.00	47.00	6.00
6.003	GG106.TT10.200.22.80.L	Tr10	2.00	8.00	2.95	0.75	5.95	1.25	22.00	47.00	6.00
6.004	GG106.TT10.200.32.80.L	Tr10	2.00	8.00	2.95	0.75	5.95	1.25	32.00	57.00	6.00
6.005	GG106.TT10.300.22.70.L	Tr10	3.00	7.00	2.95	1.10	5.95	1.75	22.00	47.00	6.00
6.006	GG106.TT10.300.32.70.L	Tr10	3.00	7.00	2.95	1.10	5.95	1.75	32.00	57.00	6.00



Round shank holder, 4 clamping surfaces

- Shank-Ø 20-25, for cutting insert type 107
- with internal coolant delivery

Type GB 106

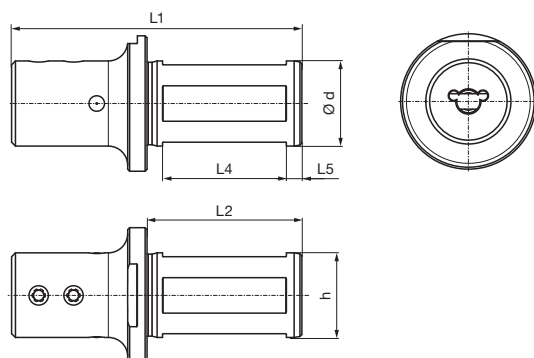

System 106

Article no. **25302**

Code no.	Description	d	h	L1	L2	L4	L5
		mm	mm	mm	mm	mm	mm
6.001	GB106.0020.075.00.22.S.IK	20.00	18.00	75.00	40.00	32.00	4.00
6.002	GB106.0022.075.00.22.S.IK	22.00	20.00	75.00	40.00	32.00	4.00
6.003	GB106.0025.075.00.22.S.IK	25.00	23.00	75.00	40.00	32.00	4.00

Spare parts

Article no.	Clamping screw	Tightening torque
25900		Nm
Code 6.000	M6x7.5x15IP	4-4.5

Article no.	Torx-Plus Wrench
25904	
Code 15.000	T15IP T-handle



Cutting insert for broaching longitudinal slots

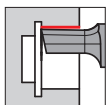

• from hole-Ø 6, tolerance class C11, P9, JS9

for tool holders type GB106 Art. No. 25302 see page 71

Tool material	Solid carbide			
Type	GN 106	GN 106	GN 106	GN 106
Surface	S	a	C	○
	TiN	TiAlN-nanoA	TiCN	bright

System 106

GUHRING NAVIGATOR

Cutting data page 94

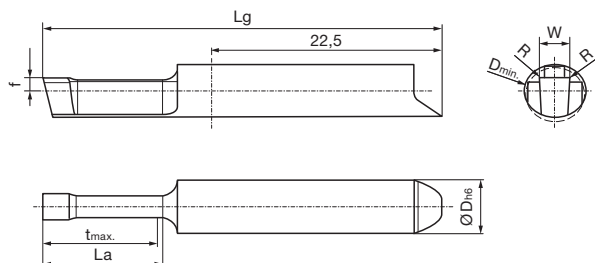

Article no. **25812** **25813** **25814** **25815**

Code no.	Description	for slot width	D min	W	R	f	t max	La	Lg	D h6
			mm	mm	mm	mm	mm	mm	mm	mm
6.001	GN106.0198.010.12.06.N	2 P9	6.00	1.98	0.10	1.50	11.50	12.00	37.00	6.00
6.002	GN106.0298.010.12.06.N	3 P9	6.00	2.98	0.10	1.50	11.50	12.00	37.00	6.00
6.003	GN106.0398.010.12.06.N	4 P9	6.00	3.98	0.10	1.50	11.50	12.00	37.00	6.00
6.004	GN106.0498.020.12.07.N	5 P9	7.00	4.98	0.20	1.50	11.50	12.00	37.00	6.00

Article no. **25816** **25817** **25818** **25819**

Code no.	Description	for slot width	D min	W	R	f	t max	La	Lg	D h6
			mm	mm	mm	mm	mm	mm	mm	mm
6.001	GN106.0200.010.12.06.N	2 JS9	6.00	2.00	0.10	1.50	11.50	12.00	37.00	6.00
6.002	GN106.0300.010.12.06.N	3 JS9	6.00	3.00	0.10	1.50	11.50	12.00	37.00	6.00
6.003	GN106.0400.010.12.06.N	4 JS9	6.00	4.00	0.10	1.50	11.50	12.00	37.00	6.00
6.004	GN106.0500.020.12.07.N	5 JS9	7.00	5.00	0.20	1.50	11.50	12.00	37.00	6.00

Article no. **25820** **25821** **25822** **25823**

Code no.	Description	for slot width	D min	W	R	f	t max	La	Lg	D h6
			mm	mm	mm	mm	mm	mm	mm	mm
6.001	GN106.0211.035.12.06.N	2 C11	6.00	2.11	0.35	1.50	11.50	12.00	37.00	6.00
6.002	GN106.0311.035.12.06.N	3 C11	6.00	3.11	0.35	1.50	11.50	12.00	37.00	6.00
6.003	GN106.0413.050.12.06.N	4 C11	6.00	4.13	0.50	1.50	11.50	12.00	37.00	6.00
6.004	GN106.0513.050.12.07.N	5 C11	7.00	5.13	0.50	1.50	11.50	12.00	37.00	6.00

SPECIAL SOLUTIONS made to measure

manufactured for you at short notice and cost-effectively.

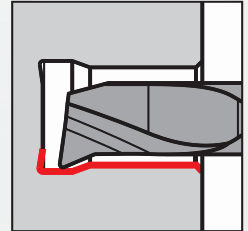

**Copying a radius at the bottom
of a bore on a turning centre**

Insert: GT 106

305





SYSTEM 305

GROOVING AND PARTING OFF



Tool holder

System 305

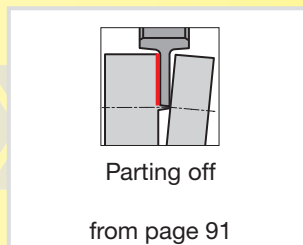
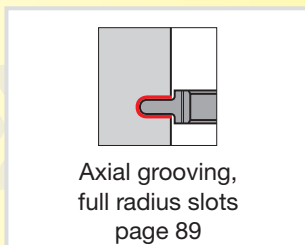
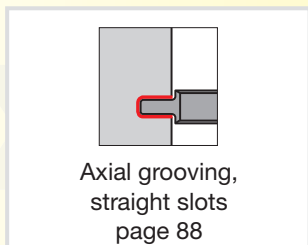
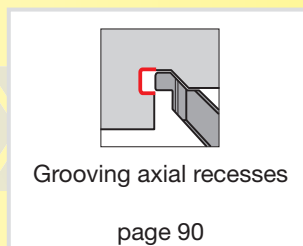
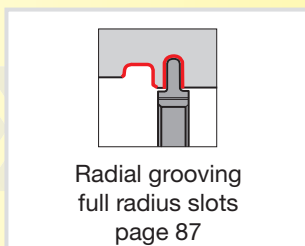
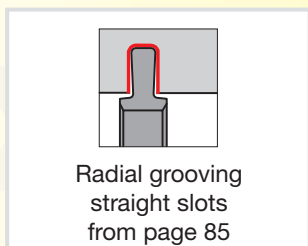

Indexable inserts



Square shank holder straight, external machining, without IC

- Shank 16x16 - 25x25, grooving depth up to 5 mm
- without internal coolant delivery

Type GH 305

for indexable inserts type 305 see from page 85

System 305

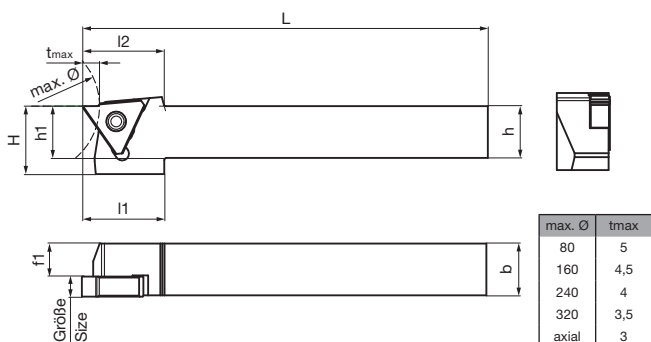

Right hand version shown
Left hand version mirror image

Article no. **25350**

version right-hand

Code no.	Description	t max	h	b	L	h1	H	l1	l2	f1	Size
		mm	mm	mm	mm	mm	mm	mm	mm	mm	
12.001	GH305.1616.125.00.04.R	5.00	16.00	16.00	125.00	16.00	21.00	25.00	25.00	12.20	04
12.002	GH305.2020.125.00.04.R	5.00	20.00	20.00	125.00	20.00	25.00	25.00	25.00	16.20	04
12.003	GH305.2525.150.00.04.R	5.00	25.00	25.00	150.00	25.00	30.00	25.00	25.00	21.20	04
12.004	GH305.1616.125.00.06.R	5.00	16.00	16.00	125.00	16.00	21.00	25.00	25.00	10.20	06
12.005	GH305.2020.125.00.06.R	5.00	20.00	20.00	125.00	20.00	25.00	25.00	25.00	14.20	06
12.006	GH305.2525.150.00.06.R	5.00	25.00	25.00	150.00	25.00	30.00	25.00	25.00	19.20	06

Article no. **25351**

version left-hand

Code no.	Description	t max	h	b	L	h1	H	l1	l2	f1	Size
		mm	mm	mm	mm	mm	mm	mm	mm	mm	
12.001	GH305.1616.125.00.04.L	5.00	16.00	16.00	125.00	16.00	21.00	25.00	25.00	12.20	04
12.002	GH305.2020.125.00.04.L	5.00	20.00	20.00	125.00	20.00	25.00	25.00	25.00	16.20	04
12.003	GH305.2525.150.00.04.L	5.00	25.00	25.00	150.00	25.00	30.00	25.00	25.00	21.20	04
12.004	GH305.1616.125.00.06.L	5.00	16.00	16.00	125.00	16.00	21.00	25.00	25.00	10.20	06
12.005	GH305.2020.125.00.06.L	5.00	20.00	20.00	125.00	20.00	25.00	25.00	25.00	14.20	06
12.006	GH305.2525.150.00.06.L	5.00	25.00	25.00	150.00	25.00	30.00	25.00	25.00	19.20	06

Spare parts

Article no.	Clamping screw	Tightening torque
25901		Nm
Code 4.000	M4x15x42x15IP	4-4.5

Article no.	Torx-Plus Wrench
25904	
Code 15.000	T15IP T-handle



Square shank holder straight, external machining, with IC

- Shank 16x16 - 25x25, grooving depth up to 5 mm
- with internal coolant delivery from above and below

Type GH 305

for indexable inserts type 305 see from page 85

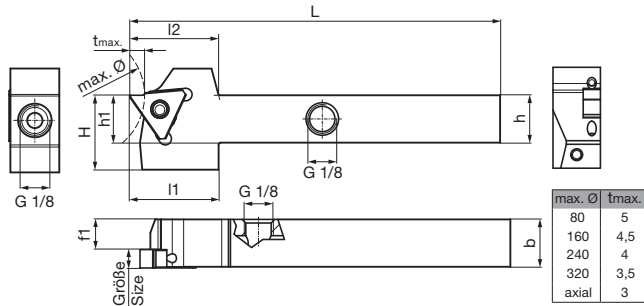

System 305

Right hand version shown
Left hand version mirror image

Article no. **25352**

version right-hand

Code no.	Description	t max	h	b	L	h1	H	l1	l2	f1	Size
		mm	mm	mm	mm	mm	mm	mm	mm	mm	
12.001	GH305.1616.125.00.04.R.IK	5.00	16.00	16.00	125.00	16.00	25.00	30.00	30.00	12.20	04
12.002	GH305.2020.125.00.04.R.IK	5.00	20.00	20.00	125.00	20.00	25.00	30.00	30.00	16.20	04
12.003	GH305.2525.150.00.04.R.IK	5.00	25.00	25.00	150.00	25.00	30.00	30.00	30.00	21.20	04
12.004	GH305.1616.125.00.06.R.IK	5.00	16.00	16.00	125.00	16.00	25.00	30.00	30.00	10.20	06
12.005	GH305.2020.125.00.06.R.IK	5.00	20.00	20.00	125.00	20.00	25.00	30.00	30.00	14.20	06
12.006	GH305.2525.150.00.06.R.IK	5.00	25.00	25.00	150.00	25.00	30.00	30.00	30.00	19.20	06

Article no. **25353**

version left-hand

Code no.	Description	t max	h	b	L	h1	H	l1	l2	f1	Size
		mm	mm	mm	mm	mm	mm	mm	mm	mm	
12.001	GH305.1616.125.00.04.L.IK	5.00	16.00	16.00	125.00	16.00	25.00	30.00	30.00	12.20	04
12.002	GH305.2020.125.00.04.L.IK	5.00	20.00	20.00	125.00	20.00	25.00	30.00	30.00	16.20	04
12.003	GH305.2525.150.00.04.L.IK	5.00	25.00	25.00	150.00	25.00	30.00	30.00	30.00	21.20	04
12.004	GH305.1616.125.00.04.L.IK	5.00	16.00	16.00	125.00	16.00	25.00	30.00	30.00	10.20	06
12.005	GH305.2020.125.00.06.L.IK	5.00	20.00	20.00	125.00	20.00	25.00	30.00	30.00	14.20	06
12.006	GH305.2525.150.00.06.L.IK	5.00	25.00	25.00	150.00	25.00	30.00	30.00	30.00	19.20	06

Spare parts

Article no.	Clamping screw	Tightening torque
25901		Nm
Code 4.000	M4x15x42x15IP	4-4.5

Article no.	Torx-Plus Wrench
25904	
Code 15.000	T15IP T-handle



Square shank holder straight, external machining, IC adjustable

- Shank 16x16 - 25x25, grooving depth up to 5 mm
- with internal coolant delivery

Type GH 305

for indexable inserts type 305 see from page 85

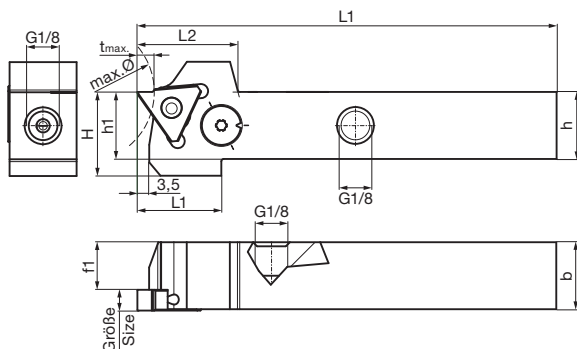

Right hand version shown
Left hand version mirror image

Article no. **25372**

version right-hand

Code no.	Description	t max	h	b	L	h1	H	l1	l2	f1	Size
		mm	mm	mm	mm	mm	mm	mm	mm	mm	
12.002	GH305.2020.125.00.04.R.IK.EST	5.00	20.00	20.00	125.00	20.00	25.00	30.00	30.00	16.20	04
12.003	GH305.2525.150.00.04.R.IK.EST	5.00	25.00	25.00	150.00	25.00	30.00	30.00	30.00	21.20	04
12.005	GH305.2020.125.00.06.R.IK.EST	5.00	20.00	20.00	125.00	20.00	25.00	30.00	30.00	14.20	06
12.006	GH305.2525.150.00.06.R.IK.EST	5.00	25.00	25.00	150.00	25.00	30.00	30.00	30.00	19.20	06

Article no. **25373**

version left-hand

Code no.	Description	t max	h	b	L	h1	H	l1	l2	f1	Size
		mm	mm	mm	mm	mm	mm	mm	mm	mm	
12.002	GH305.2020.125.00.04.L.IK.EST	5.00	20.00	20.00	125.00	20.00	25.00	30.00	30.00	16.20	04
12.003	GH305.2525.150.00.04.L.IK.EST	5.00	25.00	25.00	150.00	25.00	30.00	30.00	30.00	21.20	04
12.005	GH305.2020.125.00.06.L.IK.EST	5.00	20.00	20.00	125.00	20.00	25.00	30.00	30.00	14.20	06
12.006	GH305.2525.150.00.06.L.IK.EST	5.00	25.00	25.00	150.00	25.00	30.00	30.00	30.00	19.20	06

Spare parts

Article no.	Clamping screw	Tightening torque
25901		Nm
Code 4.000	M4x15x42x15IP	4-4.5

Article no.	Torx-Plus Wrench
25904	
Code 15.000	T15IP T-handle

System 305



Square shank holder 90° offset, external machining, without IC

- Shank 16x16 - 25x25, grooving depth up to 3.5 mm
- without internal coolant delivery

Type GH 305

for indexable inserts type 305 see from page 85

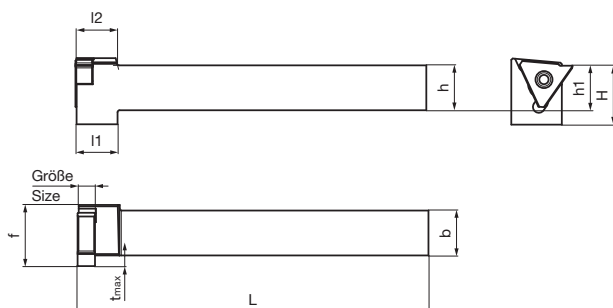

System 305

Right hand version shown
Left hand version mirror image

Article no. **25356**

version right-hand

Code no.	Description	t max	h	b	L	h1	H	l1	l2	f	Size
		mm	mm	mm	mm	mm	mm	mm	mm	mm	
12.001	GH305.1616.125.90.04.R	3.50	16.00	16.00	125.00	16.00	21.00	14.60	14.60	19.80	04
12.002	GH305.2020.125.90.04.R	3.50	20.00	20.00	125.00	20.00	25.00	14.60	14.60	23.80	04
12.003	GH305.2525.150.90.04.R	3.50	25.00	25.00	150.00	25.00	30.00	14.60	14.60	28.80	04
12.004	GH305.1616.125.90.06.R	3.50	16.00	16.00	125.00	16.00	21.00	14.60	14.60	19.80	06
12.005	GH305.2020.125.90.06.R	3.50	20.00	20.00	125.00	20.00	25.00	14.60	14.60	23.80	06
12.006	GH305.2525.150.90.06.R	3.50	25.00	25.00	150.00	25.00	30.00	14.60	14.60	28.80	06

Article no. **25357**

version left-hand

Code no.	Description	t max	h	b	L	h1	H	l1	l2	f	Size
		mm	mm	mm	mm	mm	mm	mm	mm	mm	
12.001	GH305.1616.125.90.04.L	3.50	16.00	16.00	125.00	16.00	21.00	14.60	14.60	19.80	04
12.002	GH305.2020.125.90.04.L	3.50	20.00	20.00	125.00	20.00	25.00	14.60	14.60	23.80	04
12.003	GH305.2525.150.90.04.L	3.50	25.00	25.00	150.00	25.00	30.00	14.60	14.60	28.80	04
12.004	GH305.1616.125.90.06.L	3.50	16.00	16.00	125.00	16.00	21.00	14.60	14.60	19.80	06
12.005	GH305.2020.125.90.06.L	3.50	20.00	20.00	125.00	20.00	25.00	14.60	14.60	23.80	06
12.006	GH305.2525.150.90.06.L	3.50	25.00	25.00	150.00	25.00	30.00	14.60	14.60	28.80	06

Spare parts

Article no.	Clamping screw	Tightening torque
25901		Nm
Code 4.000	M4x15x42x15IP	4-4.5

Article no.	Torx-Plus Wrench
25904	
Code 15.000	T15IP T-handle



Square shank holder 90° offset, external machining, with IC

- Shank 16x16 - 25x25, grooving depth up to 3.5 mm
- with internal coolant delivery from above and below

Type GH 305

for indexable inserts type 305 see from page 85

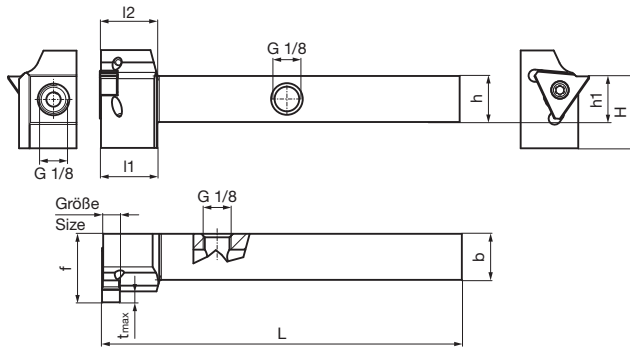

System 305

Right hand version shown
Left hand version mirror image

Article no. **25358**

version right-hand

Code no.	Description	t max	h	b	L	h1	H	l1	l2	f	Size
		mm	mm	mm	mm	mm	mm	mm	mm	mm	
12.001	GH305.1616.125.90.04.R.IK	3.50	16.00	16.00	125.00	16.00	25.00	19.60	19.60	23.80	04
12.002	GH305.2020.125.90.04.R.IK	3.50	20.00	20.00	125.00	20.00	25.00	19.60	19.60	23.80	04
12.003	GH305.2525.150.90.04.R.IK	3.50	25.00	25.00	150.00	25.00	30.00	19.60	19.60	28.80	04
12.004	GH305.1616.125.90.06.R.IK	3.50	16.00	16.00	125.00	16.00	25.00	19.60	19.60	23.80	06
12.005	GH305.2020.125.90.06.R.IK	3.50	20.00	20.00	125.00	20.00	25.00	19.60	19.60	23.80	06
12.006	GH305.2525.150.90.06.R.IK	3.50	25.00	25.00	150.00	25.00	30.00	19.60	19.60	28.80	06

Article no. **25359**

version left-hand

Code no.	Description	t max	h	b	L	h1	H	l1	l2	f	Size
		mm	mm	mm	mm	mm	mm	mm	mm	mm	
12.001	GH305.1616.125.90.04.L.IK	3.50	16.00	16.00	125.00	16.00	25.00	19.60	19.60	23.80	04
12.002	GH305.2020.125.90.04.L.IK	3.50	20.00	20.00	125.00	20.00	25.00	19.60	19.60	23.80	04
12.003	GH305.2525.150.90.04.L.IK	3.50	25.00	25.00	150.00	25.00	30.00	19.60	19.60	28.80	04
12.004	GH305.1616.125.90.06.L.IK	3.50	16.00	16.00	125.00	16.00	25.00	19.60	19.60	23.80	06
12.005	GH305.2020.125.90.06.L.IK	3.50	20.00	20.00	125.00	20.00	25.00	19.60	19.60	23.80	06
12.006	GH305.2525.150.90.06.L.IK	3.50	25.00	25.00	150.00	25.00	30.00	19.60	19.60	28.80	06

Spare parts

Article no.	Clamping screw	Tightening torque
25901		Nm
Code 4.000	M4x15x42x15IP	4-4.5

Article no.	Torx-Plus Wrench
25904	
Code 15.000	T15IP T-handle



Square shank holder 45° offset, external machining, without IC

- Shank 16x16 - 25x25, grooving depth up to 2 mm
- without internal coolant delivery

Type GH 305

for indexable inserts type 305 see page 90

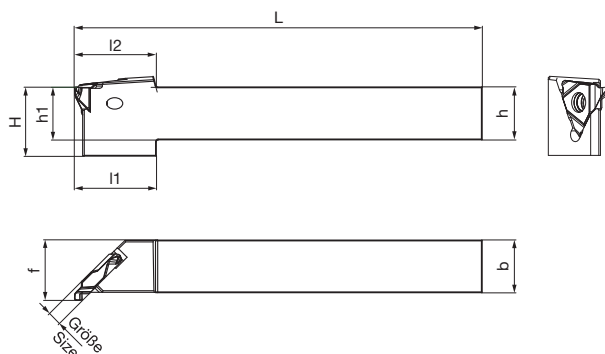

System 305

Right hand version shown
Left hand version mirror image

Article no. **25362**

version right-hand

Code no.	Description	h	b	L	h1	H	l1	l2	f	Size
		mm	mm	mm	mm	mm	mm	mm	mm	
12.001	GH305.1616.125.45.04.R	16.00	16.00	125.00	16.00	21.00	25.00	25.66	18.40	04
12.002	GH305.2020.125.45.04.R	20.00	20.00	125.00	20.00	25.00	25.00	25.66	22.40	04
12.003	GH305.2525.150.45.04.R	25.00	25.00	150.00	25.00	30.00	30.00	30.66	27.40	04

Article no. **25363**

version left-hand

Code no.	Description	h	b	L	h1	H	l1	l2	f	Size
		mm	mm	mm	mm	mm	mm	mm	mm	
12.001	GH305.1616.125.45.04.L	16.00	16.00	125.00	16.00	21.00	25.00	25.66	18.40	04
12.002	GH305.2020.125.45.04.L	20.00	20.00	125.00	20.00	25.00	25.00	25.66	22.40	04
12.003	GH305.2525.150.45.04.L	25.00	25.00	150.00	25.00	30.00	30.00	30.66	27.40	04

Spare parts

Article no.	Clamping screw	Tightening torque
25902		Nm
Code 4.001	M4x0.5x7x42x15IP	3-3.5

Article no.	Torx-Plus Wrench
25904	
Code 15.000	T15IP T-handle



Square shank holder 45° offset, external machining, with IC

- Shank 16x16 - 25x25, grooving depth up to 2 mm
- with internal coolant delivery from above

Type GH 305

for indexable inserts type 305 see page 90

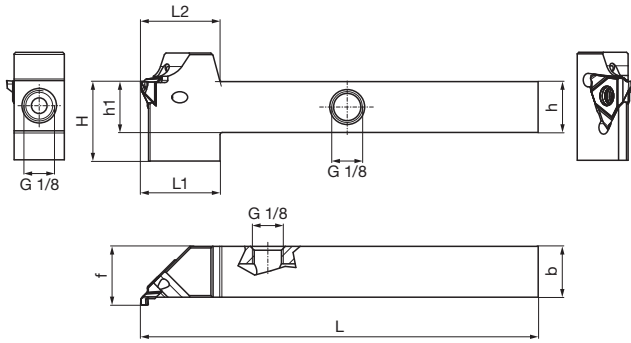

Right hand version shown
Left hand version mirror image



Article no. **25364**

version right-hand

Code no.	Description	h	b	L	h1	H	l1	l2	f	Size
		mm	mm	mm	mm	mm	mm	mm	mm	
12.001	GH305.1616.125.45.04.R.IK	16.00	16.00	125.66	16.00	25.00	25.66	25.66	18.56	04
12.002	GH305.2020.125.45.04.R.IK	20.00	20.00	125.66	20.00	25.00	25.66	25.66	22.56	04
12.003	GH305.2525.150.45.04.R.IK	25.00	25.00	150.66	25.00	30.00	30.66	30.66	27.56	04

Article no. **25365**

version left-hand

Code no.	Description	h	b	L	h1	H	l1	l2	f	Size
		mm	mm	mm	mm	mm	mm	mm	mm	
12.001	GH305.1616.125.45.04.L.IK	16.00	16.00	125.66	16.00	25.00	25.66	25.66	18.56	04
12.002	GH305.2020.125.45.04.L.IK	20.00	20.00	125.66	20.00	25.00	25.66	25.66	22.56	04
12.003	GH305.2525.150.45.04.L.IK	25.00	25.00	150.66	25.00	30.00	30.66	30.66	27.56	04

Spare parts

Article no.	Clamping screw	Tightening torque
25902		Nm
Code 4.001	M4x0.5x7x42x15IP	3-3.5

Article no.	Torx-Plus Wrench
25904	
Code 15.000	T15IP T-handle



Round shank holder, internal machining, without IC

- Shank-Ø 20-32, grooving depth up to 4 mm
- without internal coolant delivery

Type GB 305

for indexable inserts type 305 see from page 85

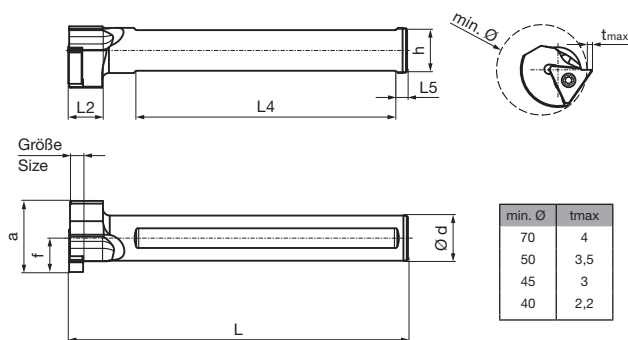

System 305

Right hand version shown
Left hand version mirror image

Article no. **25368**

version right-hand

Code no.	Description	d	L	L2	L4	L5	h	f	a	Size
		mm	mm	mm	mm	mm	mm	mm	mm	
12.001	GB305.0020.150.90.04.R	20.00	150.00	14.60	115.00	5.00	18.00	15.00	31.50	04
12.002	GB305.0025.170.90.04.R	25.00	170.00	14.60	130.00	5.00	23.00	17.50	34.50	04
12.003	GB305.0032.200.90.04.R	32.00	200.00	14.60	160.00	5.00	30.00	21.00	39.25	04
12.004	GB305.0020.150.90.06.R	20.00	150.00	14.60	115.00	5.00	18.00	15.00	31.50	06
12.005	GB305.0025.170.90.06.R	25.00	170.00	14.60	130.00	5.00	23.00	17.50	34.50	06
12.006	GB305.0032.200.90.06.R	32.00	200.00	14.60	160.00	5.00	30.00	21.00	39.25	06

Article no. **25369**

version left-hand

Code no.	Description	d	L	L2	L4	L5	h	f	a	Size
		mm	mm	mm	mm	mm	mm	mm	mm	
12.001	GB305.0020.150.90.04.L	20.00	150.00	14.60	115.00	5.00	18.00	15.00	31.50	04
12.002	GB305.0025.170.90.04.L	25.00	170.00	14.60	130.00	5.00	23.00	17.50	34.50	04
12.003	GB305.0032.200.90.04.L	32.00	200.00	14.60	160.00	5.00	30.00	21.00	39.25	04
12.004	GB305.0020.150.90.06.L	20.00	150.00	14.60	115.00	5.00	18.00	15.00	31.50	06
12.005	GB305.0025.170.90.06.L	25.00	170.00	14.60	130.00	5.00	23.00	17.50	34.50	06
12.006	GB305.0032.200.90.06.L	32.00	200.00	14.60	160.00	5.00	30.00	21.00	39.25	06

Spare parts

Article no.	Clamping screw	Tightening torque
25901		Nm
Code 4.000	M4x15x42x15IP	4-4.5

Article no.	Torx-Plus Wrench
25904	
Code 15.000	T15IP T-handle



Round shank holder, internal machining, with IC

- Shank-Ø 20-32, grooving depth up to 4 mm
- with internal coolant delivery from above

Type GB 305

for indexable inserts type 305 see from page 85

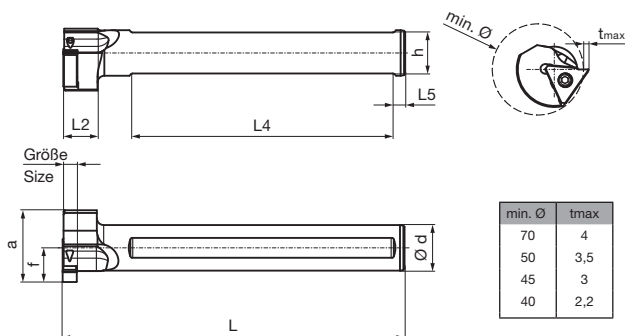

Right hand version shown
Left hand version mirror image

Article no. **25370**

version right-hand

Code no.	Description	d	L	L2	L4	L5	h	f	a	Size
		mm	mm	mm	mm	mm	mm	mm	mm	
12.001	GB305.0020.150.90.04.R	20.00	150.00	14.60	115.00	5.00	18.00	15.00	31.50	04
12.002	GB305.0025.170.90.04.R	25.00	170.00	14.60	130.00	5.00	23.00	17.50	34.50	04
12.003	GB305.0032.200.90.04.R	32.00	200.00	14.60	160.00	5.00	30.00	21.00	39.25	04
12.004	GB305.0020.150.90.06.R	20.00	150.00	14.60	115.00	5.00	18.00	15.00	31.50	06
12.005	GB305.0025.170.90.06.R	25.00	170.00	14.60	130.00	5.00	23.00	17.50	34.50	06
12.006	GB305.0032.200.90.06.R	32.00	200.00	14.60	160.00	5.00	30.00	21.00	39.25	06

Article no. **25371**

version left-hand

Code no.	Description	d	L	L2	L4	L5	h	f	a	Size
		mm	mm	mm	mm	mm	mm	mm	mm	
12.001	GB305.0020.150.90.04.L	20.00	150.00	14.60	115.00	5.00	18.00	15.00	31.50	04
12.002	GB305.0025.170.90.04.L	25.00	170.00	14.60	130.00	5.00	23.00	17.50	34.50	04
12.003	GB305.0032.200.90.04.L	32.00	200.00	14.60	160.00	5.00	30.00	21.00	39.25	04
12.004	GB305.0020.150.90.06.L	20.00	150.00	14.60	115.00	5.00	18.00	15.00	31.50	06
12.005	GB305.0025.170.90.06.L	25.00	170.00	14.60	130.00	5.00	23.00	17.50	34.50	06
12.006	GB305.0032.200.90.06.L	32.00	200.00	14.60	160.00	5.00	30.00	21.00	39.25	06

Spare parts

Article no.	Clamping screw	Tightening torque
25901		Nm
Code 4.000	M4x15x42x15IP	4-4.5

Article no.	Torx-Plus Wrench
25904	
Code 15.000	T15IP T-handle

System 305



Indexable insert for radial grooving external and internal

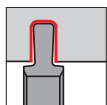

- Snap ring grooves to DIN471/472, NW = 0.5-5.15
- Indexable insert applicable in right and left holders
- Geometry .BA ground
- Pay attention to insert seat size 04 / 06

for tool holders type GH305/GB305 see from page 76

GUHRING NAVIGATOR

Cutting data page 94

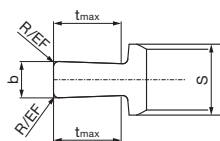
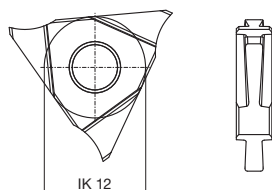

System 305

Article no. **25601** **25602** **25603**

Code no.	Description	NW	b ±0,02	R	EF	t max	s	Size
		mm	mm	mm	mm	mm	mm	
12.001	GE305.0050.000.BA.04.N	0.50	0.55			1.50	4.20	04
12.002	GE305.0060.000.BA.04.N	0.60	0.65			1.50	4.20	04
12.003	GE305.0070.000.BA.04.N	0.70	0.75			1.50	4.20	04
12.004	GE305.0080.000.BA.04.N	0.80	0.85			1.50	4.20	04
12.005	GE305.0090.000.BA.04.N	0.90	0.95			1.50	4.20	04
12.006	GE305.0100.000.BA.04.N	1.00	1.05		0.05	3.00	4.20	04
12.007	GE305.0110.000.BA.04.N	1.10	1.22		0.05	3.00	4.20	04
12.008	GE305.0130.000.BA.04.N	1.30	1.42		0.05	3.00	4.20	04
12.009	GE305.0160.000.BA.04.N	1.60	1.72		0.05	4.00	4.20	04
12.010	GE305.0185.015.BA.04.N	1.85	1.97	0.15		4.00	4.20	04
12.011	GE305.0215.015.BA.04.N	2.15	2.27	0.15		5.00	4.20	04
12.012	GE305.0265.015.BA.04.N	2.65	2.77	0.15		5.00	4.20	04
12.013	GE305.0315.015.BA.04.N	3.15	3.27	0.15		5.00	4.20	04
12.014	GE305.0415.015.BA.06.N	4.15	4.27	0.15		5.00	6.20	06
12.015	GE305.0515.015.BA.06.N	5.15	5.27	0.15		5.00	6.20	06



Indexable insert for radial grooving and copying external and internal

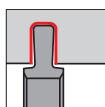

- Grooving width 1.0-4.0 mm, grooving depth up to 5 mm
- Indexable insert applicable in right and left holders
- Geometry .BA ground

for tool holders type GH305/GB305 size 04 see from page 76

GUHRING NAVIGATOR

Cutting data page 94

Tool material	Solid carbide		
Type	GE 305	GE 305	GE 305
Surface			
	FIRE	TICN	bright

System 305

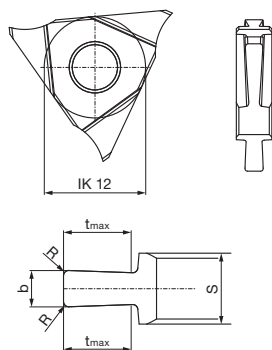

Article no. **25605** **25606** **25607**

Code no.	Description	b ±0,02	R	t max	s	Size
		mm	mm	mm	mm	
12.001	GE305.0100.010.BA.04.N	1.00	0.10	3.00	4.20	04
12.002	GE305.0150.020.BA.04.N	1.50	0.20	3.00	4.20	04
12.003	GE305.0200.020.BA.04.N	2.00	0.20	4.00	4.20	04
12.004	GE305.0250.030.BA.04.N	2.50	0.30	5.00	4.20	04
12.005	GE305.0300.030.BA.04.N	3.00	0.30	5.00	4.20	04
12.006	GE305.0350.030.BA.04.N	3.50	0.30	5.00	4.20	04
12.007	GE305.0400.020.BA.04.N	4.00	0.20	5.00	4.20	04
12.008	GE305.0400.040.BA.04.N	4.00	0.40	5.00	4.20	04



Indexable insert for radial grooving and copying external and internal

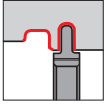

- Full radius R0.25-R2.0 mm, grooving depth up to 5 mm
- Indexable insert applicable in right and left holders
- Geometry .AA ground

for tool holders type GH305/GB305 size 04 see from page 76

GUHRING NAVIGATOR

Cutting data page 94

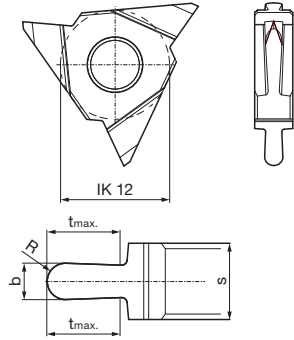

Article no. **25613** **25614** **25615**

Code no.	Description	b ±0,02	R	t max	s	Size
		mm	mm	mm	mm	
12.001	GE305.0050.025.AA.04.N	0.50	0.25	1.50	4.20	04
12.002	GE305.0100.050.AA.04.N	1.00	0.50	3.00	4.20	04
12.003	GE305.0110.055.AA.04.N	1.10	0.55	3.00	4.20	04
12.004	GE305.0120.060.AA.04.N	1.20	0.60	3.00	4.20	04
12.005	GE305.0140.070.AA.04.N	1.40	0.70	3.00	4.20	04
12.006	GE305.0150.075.AA.04.N	1.50	0.75	3.00	4.20	04
12.007	GE305.0160.080.AA.04.N	1.60	0.80	4.00	4.20	04
12.008	GE305.0180.090.AA.04.N	1.80	0.90	4.00	4.20	04
12.009	GE305.0200.100.AA.04.N	2.00	1.00	4.00	4.20	04
12.010	GE305.0220.110.AA.04.N	2.20	1.10	5.00	4.20	04
12.011	GE305.0250.125.AA.04.N	2.50	1.25	5.00	4.20	04
12.012	GE305.0280.140.AA.04.N	2.80	1.40	5.00	4.20	04
12.013	GE305.0300.150.AA.04.N	3.00	1.50	5.00	4.20	04
12.014	GE305.0360.180.AA.04.N	3.60	1.80	5.00	4.20	04
12.015	GE305.0400.200.AA.04.N	4.00	2.00	5.00	4.20	04

System 305

Indexable insert for axial grooving, straight slots

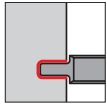

- from external slot-Ø 15, grooving depth up to 3 mm
- Indexable insert applicable in right and left holders
- Geometry .BA ground

for tool holders type GH305 size 04 see from page 76

GUHRING NAVIGATOR

Cutting data page 94

Tool material	Solid carbide		
Type	GA 305	GA 305	GA 305
Surface			
	FIRE	TiCN	bright

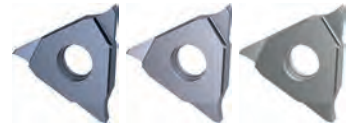
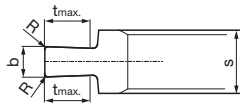
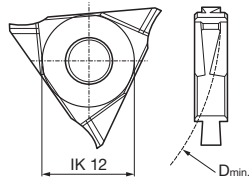

Right hand version shown
Left hand version mirror image

Article no. **25626** **25628** **25630**

Cutting direction

Code no.	Description	D min	b ±0,02	R	t max	s	Size
		mm	mm	mm	mm	mm	
12.001	GA305.0150.020.BA.04.R	15.00	1.50	0.20	2.00	4.20	04
12.002	GA305.0200.020.BA.04.R	30.00	2.00	0.20	3.00	4.20	04
12.003	GA305.0250.020.BA.04.R	30.00	2.50	0.20	3.00	4.20	04
12.004	GA305.0300.020.BA.04.R	30.00	3.00	0.20	3.00	4.20	04

Article no. **25627** **25629** **25631**

Cutting direction

Code no.	Description	D min	b ±0,02	R	t max	s	Size
		mm	mm	mm	mm	mm	
12.001	GA305.0150.020.BA.04.L	15.00	1.50	0.20	2.00	4.20	04
12.002	GA305.0200.020.BA.04.L	30.00	2.00	0.20	3.00	4.20	04
12.003	GA305.0250.020.BA.04.L	30.00	2.50	0.20	3.00	4.20	04
12.004	GA305.0300.020.BA.04.L	30.00	3.00	0.20	3.00	4.20	04



Indexable insert for axial grooving, full radius slots

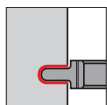

- from external slot-Ø 15, full radius R0.75-R2, grooving depth up to 3 mm
- Indexable insert applicable in right and left holders
- Geometry .AA ground

for tool holders type GH305 size 04 see from page 76

GUHRING NAVIGATOR

Cutting data page 94

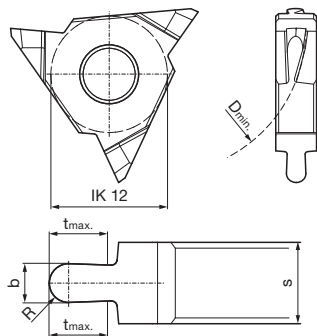

Right hand version shown
Left hand version mirror image



System 305

Article no. **25634** **25636** **25638**

Cutting direction

Code no.	Description	D min	b ±0,02	R	t max	s	Size
		mm	mm	mm	mm	mm	
12.001	GA305.0150.075.AA.04.R	15.00	1.50	0.75	2.00	4.20	04
12.002	GA305.0200.100.AA.04.R	30.00	2.00	1.00	3.00	4.20	04
12.003	GA305.0300.150.AA.04.R	30.00	3.00	1.50	3.00	4.20	04
12.004	GA305.0400.200.AA.04.R	30.00	4.00	2.00	3.00	4.20	04

Article no. **25635** **25637** **25639**

Cutting direction

Code no.	Description	D min	b ±0,02	R	t max	s	Size
		mm	mm	mm	mm	mm	
12.001	GA305.0150.075.AA.04.L	15.00	1.50	0.75	2.00	4.20	04
12.002	GA305.0200.100.AA.04.L	30.00	2.00	1.00	3.00	4.20	04
12.003	GA305.0300.150.AA.04.L	30.00	3.00	1.50	3.00	4.20	04
12.004	GA305.0400.200.AA.04.L	30.00	4.00	2.00	3.00	4.20	04

Indexable insert for grooving axial external recesses

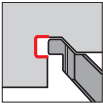

- from external slot-Ø 8, grooving depth up to 2 mm
- right index. inserts in rh, left index. inserts in lh tool holders
- Geometry .AA ground
- for axial external recesses to ISO 9974-2

for tool holders type GH305, 45° depressed centre, see page 81

GUHRING NAVIGATOR

Cutting data page 94

Tool material	Solid carbide		
Type	GA 305	GA 305	GA 305
Surface			
	FIRE	TICN	bright

System 305

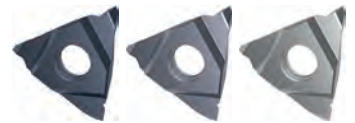
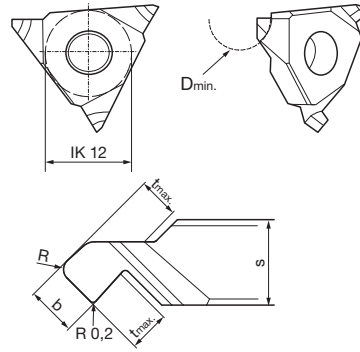

Right hand version shown
Left hand version mirror image

Article no. **25618** **25620** **25622**

Cutting direction

Code no.	Description	D min	b ±0,02	R	t max	s	Size
		mm	mm	mm	mm	mm	
12.001	GA305.0150.040.AA.04.R	8.00	1.50	0.40	1.60	4.20	04
12.002	GA305.0200.050.AA.04.R	12.00	2.00	0.50	1.90	4.20	04
12.003	GA305.0240.060.AA.04.R	20.00	2.40	0.60	2.00	4.20	04

Article no. **25619** **25621** **25623**

Cutting direction

Code no.	Description	D min	b ±0,02	R	t max	s	Size
		mm	mm	mm	mm	mm	
12.001	GA305.0150.040.AA.04.L	8.00	1.50	0.40	1.60	4.20	04
12.002	GA305.0200.050.AA.04.L	12.00	2.00	0.50	1.90	4.20	04
12.003	GA305.0240.060.AA.04.L	20.00	2.40	0.60	2.00	4.20	04



Indexable insert for parting off

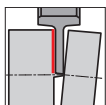

- Grooving width 1.0-1.5 mm, grooving depth 5 mm
- Indexable insert applicable in right and left holders
- Geometry .AA ground
- without front cutting angle

for tool holders type GH305 size 04 see from page 76

GUHRING NAVIGATOR

Cutting data page 94

Tool material	Solid carbide		
Type	GZ 305	GZ 305	GZ 305
Surface			
	FIRE	TICN	bright

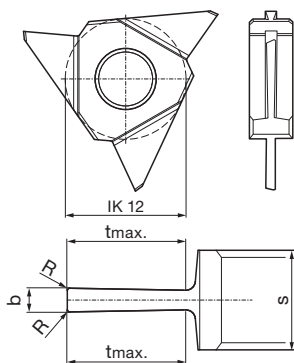

System 305

Article no. **25641** **25642** **25643**

Code no.	Description	b ±0,02	R	t max	s	Size
		mm	mm	mm	mm	
12.001	GZ305.0100.000.AA.04.N	1.00	0.10	5.00	4.20	04
12.002	GZ305.0150.000.AA.04.N	1.50	0.10	5.00	4.20	04

Indexable insert for parting off

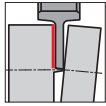

- Grooving width 1.0-1.5 mm, grooving depth 5 mm
- Indexable insert applicable in right and left holders
- Geometry .AA ground
- with front cutting angle

for tool holders type GH305 size 04 see from page 76

GUHRING NAVIGATOR

Cutting data page 94

Tool material	Solid carbide		
Type	GZ 305	GZ 305	GZ 305
Surface			
	FIRE	TICN	bright

System 305

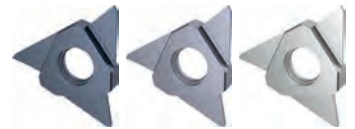
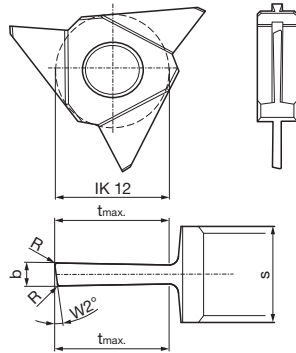

Right hand version shown
Left hand version mirror image

Article no.	25646	25648	25650
version	right-hand	right-hand	right-hand

Code no.	Description	b ±0,02	R	W2	t max	s	Size
		mm	mm	°	mm	mm	
12.001	GZ305.0100.080.AA.04.R	1.00	0.10	8.00	5.00	4.20	04
12.002	GZ305.0150.080.AA.04.R	1.50	0.10	8.00	5.00	4.20	04

Article no.	25647	25649	25651
version	left-hand	left-hand	left-hand

Code no.	Description	b ±0,02	R	W2	t max	s	Size
		mm	mm	°	mm	mm	
12.001	GZ305.0100.080.AA.04.L	1.00	0.10	8.00	5.00	4.20	04
12.002	GZ305.0150.080.AA.04.L	1.50	0.10	8.00	5.00	4.20	04



TECHNICAL SECTION & ACCESSORIES

Technical section
& Accessories

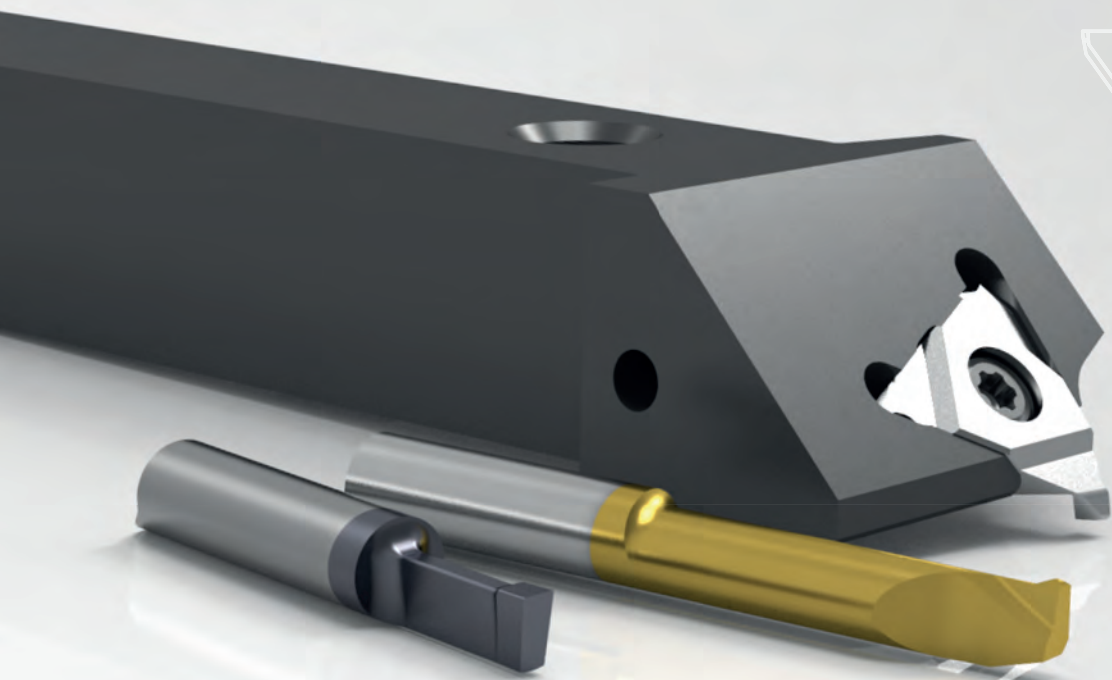



GUHRINGNAVIGATOR

SYSTEM 104/106

Machining	Feed range f (mm/U)	Point radius R	Cutting depth ap (mm)
	0.02 - 0.08	R 0.05 R 0.1 R 0.15 R 0.25	0.02 - 0.07 0.05 - 0.15 0.08 - 0.20 0.10 - 0.25
	0.01 - 0.03		
	0.01 - 0.05		

ISO	Material	Material examples/ material number	Tensile strength (N/mm ²)	Brinell hardness (HB)	Cutting speed vc (m/min)								
					TiN Ⓢ	TiCN Ⓢ	TiAlN nanoA Ⓢ	Bright Ⓢ					
P	Carbon steel	C ≤ 0.15 %	11SMn30+C / 1.0715 C15 / 1.0401	500 600	150 180	20-160	20-180	50-200	15-90				
		C ≥ 0.15 - 0.45 %	S235JR (ST37-2) / 1.0037 Ck22 / 1.1151	400 600	120 180								
		C > 0.45 %	S355JO (St52-3) / 1.0553 C60 / 1.0601	600 900	180 270								
										20-90	20-140	50-160	-
	Low-alloyed steel (alloy content ≤ 5%)	annealed	16MnCr5 / 1.7131 18CrNi8 / 1.5920	650 650	200 200	20-160	20-160	50-180	15-70				
		heat-treatable	25CrMoV4 / 1.7218 42CrMo4V / 1.7225	900 1100	270 320								
										-	30-90	30-120	-
	High-alloyed steel (alloy content > 5%)	annealed	X37CrMoV5-1 / 1.2343 X153CrMoV12 / 1.2379	750 850	220 250	25-90	30-110	40-140	-				
		heat-treatable	55NiCrMoV7 / 1.2714	1200	350					-	-	30-100	-
	Cast steel	un-alloyed, low-alloyed	GS52 / 1.0552	600	180	20-120	30-160	30-180	-				
high-alloyed		GX40CrNiSi22-10 / 1.4826	750	220	-					30-70	30-90	-	
M	Stainless steel	martensitic, ferritic, tempered	X14CrMoS17 / 1.4104 X4CrNiMo16-5-1 / 1.4418	800 1000	240 300	20-70	30-80	30-90	-				
			austenitic, Ni > 8%	X5CrNi18-10 / 1.4301 X2CrNiMo17-12-2 / 1.4404	650					200			
		austenitic, ferritic (Duplex)		X2CrNiMoCuN25-6-3 / 1.4507 X2CrNiMoN25-7-4 / 1.4410	850					250	-	-	30-100
			K	Grey cast iron	low tensile strength					EN-GJL-200 (GG20) / 0.6020		180	30-150
high tensile strength	EN-GJL-400 (GG40) / 0.6040				260								
Spheroidal graphite iron	low tensile strength	EN-GJS-400-15 (GGG40) / 0.7040			160	30-130	30-130	30-160	-				
	high tensile strength	EN-GJS-700-2 (GGG70) / 0.7070			260								
Malleable cast iron	low tensile strength	EN-GJMW-350-4 (GTW35) / 0.8035			125	30-130	30-130	30-160	-				
	high tensile strength	EN-GJMB-550-4 (GTS55) / 0.8155			250					30-110	30-110	30-140	
N	Al-alloys	non-heat-treatable <12% Si	EN-AW-2017 (AlCuMg1) / 3.1325		100	30-550	30-550	30-550	30-250				
		heat-treatable <12% Si	EN-AW-6082 (AlMgSi1) / 3.2315		100								
	Al-cast-alloys	non-heat-treatable <12% Si	AlSi9Cu3 / 3.2163		80								
		heat-treatable <12% Si	AlSi10Mg / 3.2383		100								
	Copper alloys	brass, lead alloy	CuZn39Pb2 (MS58) / 2.0380	400	120					30-400	30-400	30-400	30-180
		bronze	CuSn6 / 2.1020	500	150								
S	Heat resistant alloys, super alloys	NiFe-base, annealed	NiCr15Fe (Alloy600) / 2.4816	700		-	15-70	15-70	-				
		NiFe-Basis, hardened		950						-	15-50	15-50	
		NiCo-Basis, annealed	NiMo16Cr15W (Alloy C-276) / 2.4	800						-	15-50	15-50	
		NiCo-Basis, cast		1100						-	10-40	10-40	-
		NiCo-Basis, hardened	NiCr19NbMo (Alloy718) / 2.4668	1200						-	10-35	10-35	
	Titanium-alloys	annealed	Ti6Al4V / 3.7164	900		-	15-50	15-50	-				
		hardened		1200						-	10-35	10-35	



GUHRING NAVIGATOR

SYSTEM 305

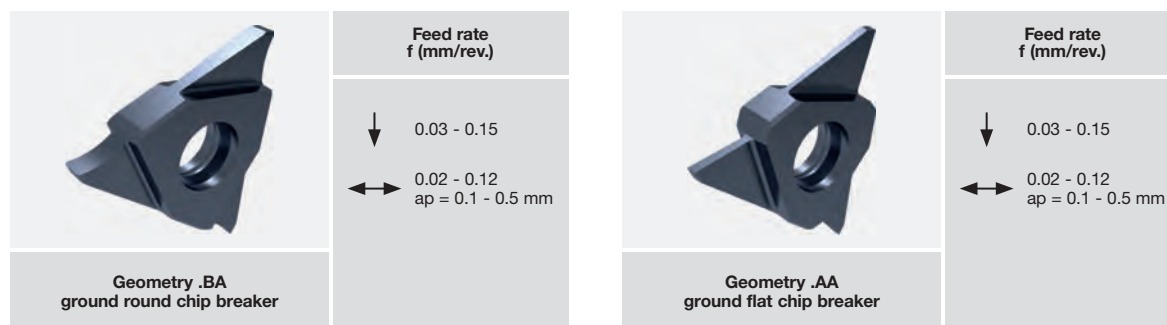

ISO	Material		Material examples/ material number	Tensile strength (N/mm ²)	Brinell hardness (HB)	Cutting speed vc (m/min)	
						FIRE/nanoFIRE Ⓢ	TiCN Ⓢ
P	Carbon steel	C < = 0.15 %	11SMn30+C / 1.0715 C15 / 1.0401	500 600	150 180	150-220	130-200
		C ≥ = 0.15-0.45 %	S235JR (ST37-2) / 1.0037 Ck22 / 1.1151	400 600	120 180		
		C > = 0.45 %	S355JO (St52-3) / 1.0553 C60 / 1.0601	600 900	180 270		
	Low-alloyed steel (alloy content ≤5%)	annealed	16MnCr5 / 1.7131 18CrNi8 / 1.5920	650 650	200 200	120-170	90-150
		heat-treatable	25CrMoV4 / 1.7218 42CrMo4V / 1.7225	900 1100	270 320		
	High-alloyed steel (alloy content >5%)	annealed	X37CrMoV5-1 / 1.2343 X153CrMoV12 / 1.2379	750 850	220 250	130-180	-
		heat-treatable	55NiCrMoV7 / 1.2714	1200	350		
	Cast steel	un-alloyed, low-alloyed	GS52 / 1.0552	600	180	130-180	-
		high-alloyed	GX40CrNiSi22-10 / 1.4826	750	220		
	M	Stainless steel	martensitic, ferritic, tempered	X14CrMoS17 / 1.4104 X4CrNiMo16-5-1 / 1.4418	800 1000	240 300	-
austenitic, Ni > 8%			X5CrNi18-10 / 1.4301 X2CrNiMo17-12-2 / 1.4404	650	200		
austenitic, ferritic (Duplex)			X2CrNiMoCuN25-6-3 / 1.4507 X2CrNiMoN25-7-4 / 1.4410	850	250		
K	Grey cast iron	low tensile strength	EN-GJL-200 (GG20) / 0.6020		180	90-150	-
		high tensile strength	EN-GJL-400 (GG40) / 0.6040		260		
	Spheroidal graphite iron	low tensile strength	EN-GJS-400-15 (GGG40) / 0.7040		160	90-150	70-100
		high tensile strength	EN-GJS-700-2 (GGG70) / 0.7070		260		
	Malleable cast iron	low tensile strength	EN-GJMW-350-4 (GTW35) / 0.8035		125	70-140	60-100
		high tensile strength	EN-GJMB-550-4 (GTS55) / 0.8155		250		
N	Al-alloys	non-heat-treatable <12% Si	EN-AW-2017 (AlCuMg1) / 3.1325		60	-	500-800
		heat-treatable <12% Si	EN-AW-6082 (AlMgSi1) / 3.2315		100		
	Al-cast-alloys	non-heat-treatable <12% Si	AlSi9Cu3 / 3.2163		80	-	500-800
		heat-treatable <12% Si	AlSi10Mg / 3.2383		100		
	Copper alloys	brass, lead alloy	CuZn39Pb2 (MS58) / 2.0380	400	120	-	130-250
		bronze	CuSn6 / 2.1020	500	150		
S	Heat resistant alloys, super alloys	NiFe-base, annealed	NiCr15Fe (Alloy600) / 2.4816	700		-	30-70
		NiFe-Basis, hardened		950			
		NiCo-Basis, annealed	NiMo16Cr15W (Alloy C-276) / 2.4819	800			
		NiCo-Basis, cast		1100			
		NiCo-Basis, hardened	NiCr19NbMo (Alloy718) / 2.4668	1200			
	Titanium-alloys	annealed	Ti6Al4V / 3.7164	900		-	30-50
		hardened		1200			



Internal threading System GG 104 and GG 106

Pitch/P		Recommended number of cuts with internal threading						
		Steel materials (tensile strength in N/mm ²)			Stainless steel	Cast iron	Heat-resistant alloys	Aluminium
mm	Gg/°	400-700	700-1150	> 1150				
0.3		3	4	5	5	3	5	3
0.5	48	5	6	8	8	5	8	5
0.8	32	7	8	9	9	7	9	7
1	24	8	9	10	10	8	10	8
1.25	19	10	11	12	12	10	12	10
1.5	16	12	13	15	15	12	15	12
1.75	14	14	15	18	18	14	18	14
2	11	16	17	20	20	16	20	16
3	8	22	24	30	30	22	30	22

Feed direction internal threading

Right-hand thread



Insert: Right-hand design
Direction of rotation: Clockwise M3 turning from outside in

Insert: Left-hand design
Direction of rotation: Anticlockwise M4 turning from inside out

Left-hand thread

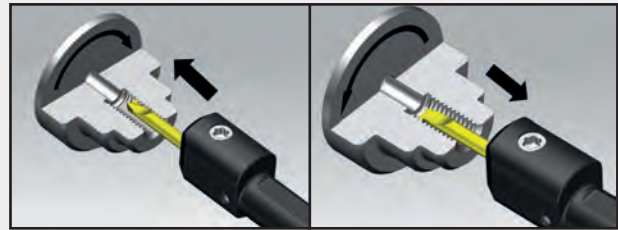

Insert: Left-hand design
Direction of rotation: Anticlockwise M4 turning from outside in

Insert: Right-hand design
Direction of rotation: Clockwise M3 turning from inside out

Feed process



Radial feed

- Both cutting edges engaged at the same time
- High cutting pressure and thermal load
- Especially suitable for the machining of short-chipping materials
- For the production of threads with a small pitch and small thread depth as well as multiple start depths to prevent pitch errors



One-sided flank in-feed

- Only one cutting edge engaged
- Lower cutting pressure and thermal load
- Especially suitable for the machining of long-chipping materials
- Achieving a higher surface finish quality at the respective thread flank

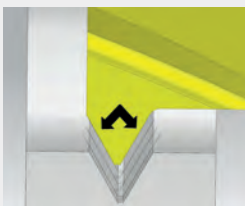

Reciprocal flank in-feed

- Both cutting edges alternately engaged
- Lower cutting pressure and thermal load
- Especially suitable for the machining of long-chipping materials
- Achieving a higher surface finish quality at the flanks



Broaching

System GN 104 and GN 106

Application instructions

- With blind holes a run-out groove / undercut or cross hole must be at the groove end to allow chip evacuation
- As a general rule the delivery of coolant (soluble or neat oil) helps the broaching process. It allows chips to be flushed out of the hole as well as increasing the surface finish quality of the slot and tool life.
- On the return stroke the tool must travel completely out of the slot.
- Pay attention to the feed \emptyset when programming the first stroke (load on the cutting corners).

Calculating the feed diameter $\emptyset d1$ for the first stroke

Example: Hole- \emptyset : 8 mm
 Groove width: 5 mm
 Safety distance between cutting corners and workpiece- \emptyset : 0,15 mm

r = radius workpiece (hole- \emptyset 8/2) = 4
 b = Cutting edge / 2 (5/2) = 2,5

Feed radius = $\sqrt{r^2 - b^2}$ - safety distance

Feed radius = $\sqrt{4^2 - 2,5^2}$ - 0,15 = 2,97

Feed diameter $\emptyset d1 = 2,97 \times 2 = \emptyset 5,94$

The feed diameter for the first stroke in the machining example above is $\emptyset 5,94$

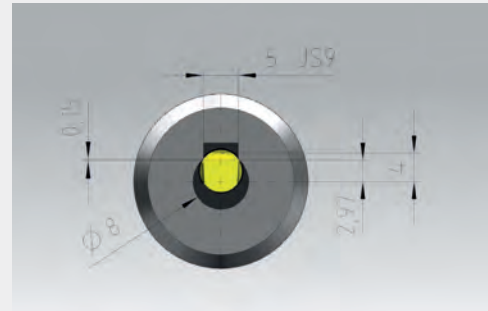

Feed and feed rate

- The feed per stroke is dependent on the tensile strength of the material to be machined.
- The feed rate when broaching corresponds to the cutting speed and is controlled by the Z-axis of the machine.
- Achievable speeds are partly limited by the machine conditions.

	Tensile strength (N/mm ²)					
	300	400	600	800	1000	1200
Feed rate (mm/min)	10000	8000	7000	6000	5000	4000
Feed per stroke (mm)	0,1	0,08	0,07	0,06	0,05	0,04

* Values are for guidance only. The machine condition, rigidity of component clamping as well as the workpiece material influence the cutting parameters.

Torque wrenches



Article no. **4915**

Size	Nm	l1 mm	Code no.
1/4"	2-8	200.000	8.000

Torx-Plus interchangeable blade



Article no. **4960**

Size	Nm	l1 mm	Code no.
T15IP		175.000	15.000

Torx-Plus screwdriver



Key with T-handle code no. 15.000 • Allen key code no. 15.001



Article no. **25904**

Size	l1 mm	Code no.
T15IP	65.000	15.000
T15IP	97.000	15.001



Clamping screws



Article no. **25900**

Size	d1	l1	Code no.
		mm	
T15IP	M6	7.500	6.000

Clamping screws



Article no. **25901**

Size	d1	l1	Code no.
		mm	
T15IP	M4	15.000	4.000

Clamping screws



Article no. **25902**

Size	d1	l1	Code no.
		mm	
T15IP	M4	7.000	4.001

Activation screws



Article no. **25905**

Size	d1	l1	Code no.
		mm	
SW 4	G1/8	5.000	5.000

SYSTEM HOLDERS & MODULAR TOOLS

manufactured for you at short notice and cost-effectively!

- suitable for all inserts type 104, type 106 and indexable inserts type 305
- system holders can be supplied with polygon, HSK-T or TS interface



System holder
HSK-T DIN ISO 12164-4

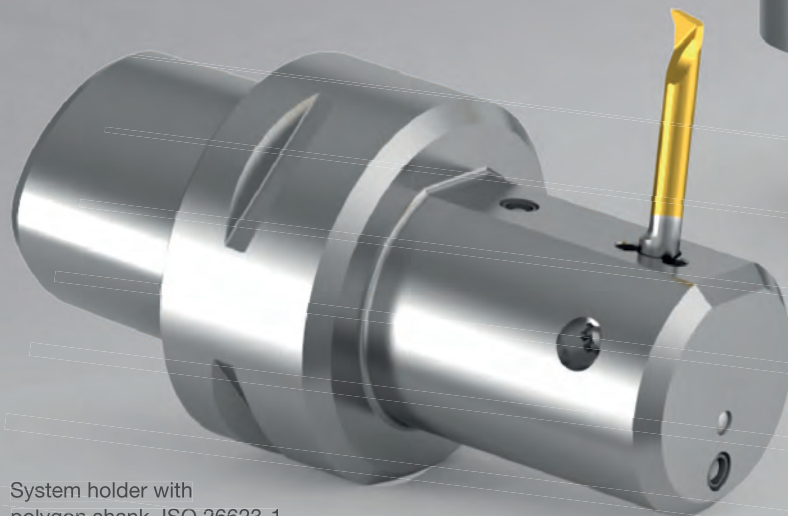

System holder with
polygon shank ISO 26623-1



System holder
TS ISO 26622-1

System holder
with polygon shank ISO 26623-1



SPECIAL SOLUTIONS made to measure

SYSTEM 104

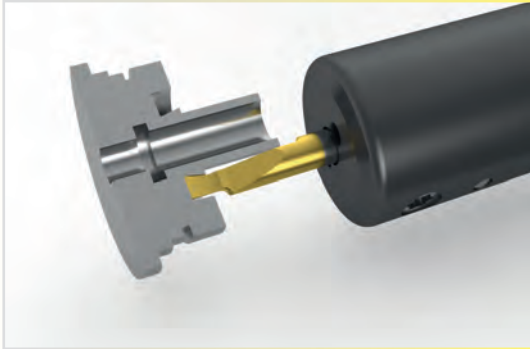

Face grooving and copying dovetail grooving

Insert: GA 104

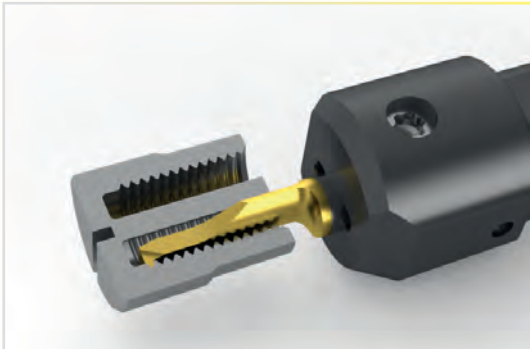

Internal threading

Insert: GG 104

SYSTEM 106



Copying a radius at the bottom of a bore on a turning centre

Insert: GT 106

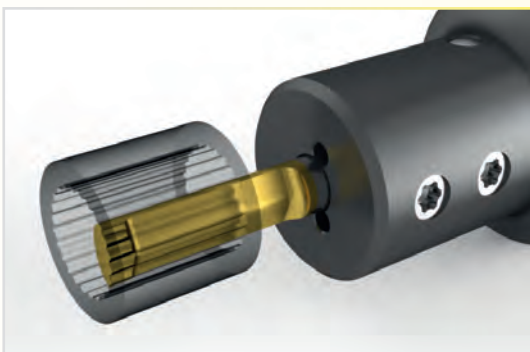

Broaching an internal spline, pre- and finish-cutter in one tool

Insert: GN 106



SYSTEM 305



Broaching an internal longitudinal grooves from hole \varnothing 30 mm,

i.e. for profile forms or tooth profiles

Clamping holder and indexable insert type 305

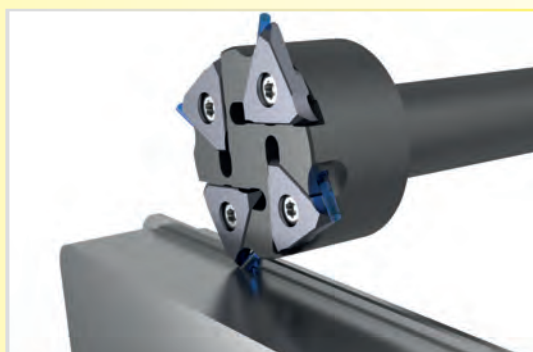

External/internal circular milling of form recesses

Milling body and indexable insert type 305



Indexable insert type 305, basic width 4.2 mm

Grooving with external edge chamfering,
form width up to 4.2 mm, form depth up to 4 mm



Indexable insert type 305, basic width 6.2 mm

Two grooves in one operation,
form width up to 6.2 mm, form depth up to 4 mm



Indexable insert type 305, basic width 8.2 mm

Profile form insert, external contour,
form width up to 8.2 mm, form depth up to 4 mm



Indexable insert type 305, basic width 12.2 mm

Profile form insert, external contour,
form width up to 12.2 mm, form depth up to 4 mm

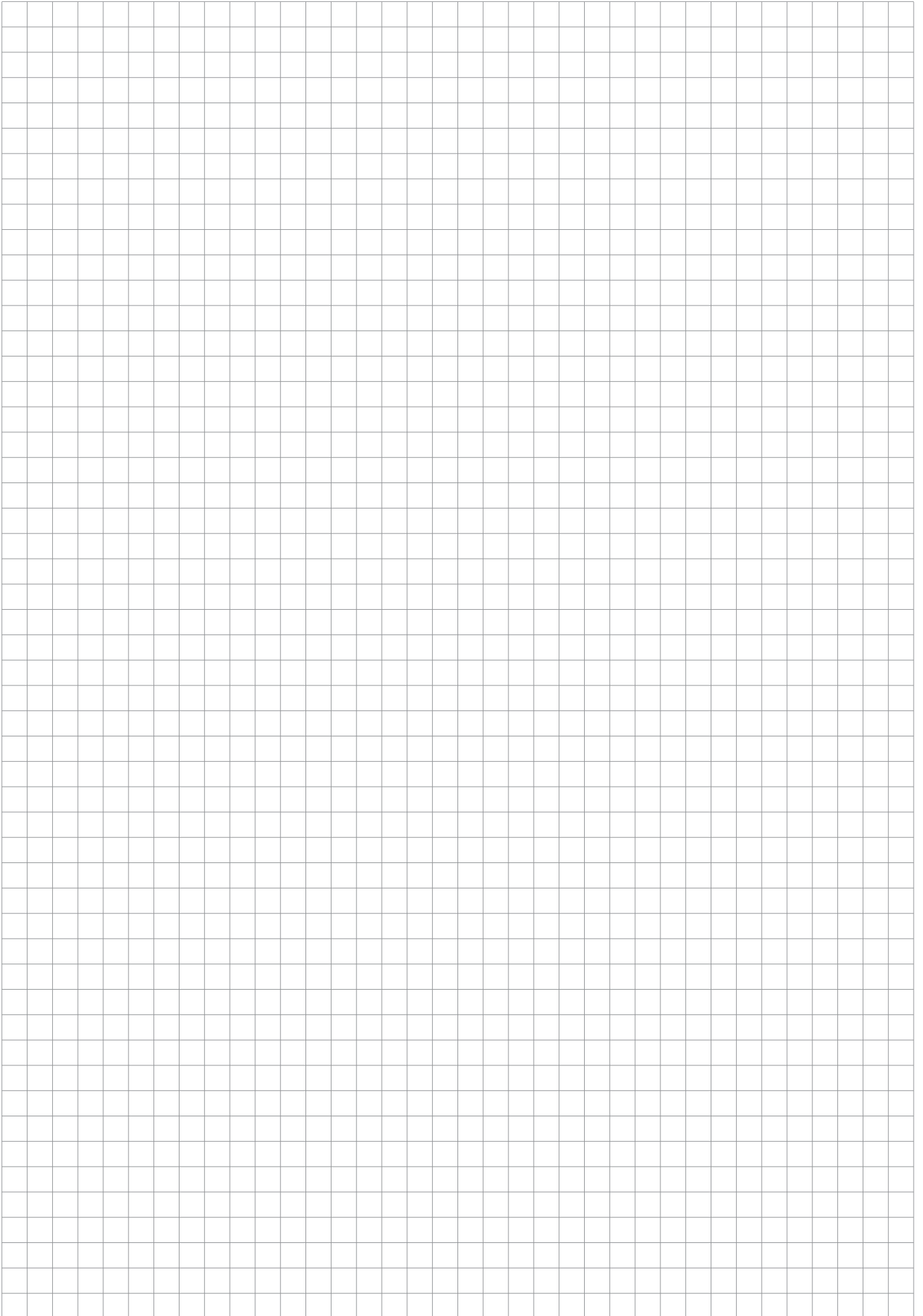

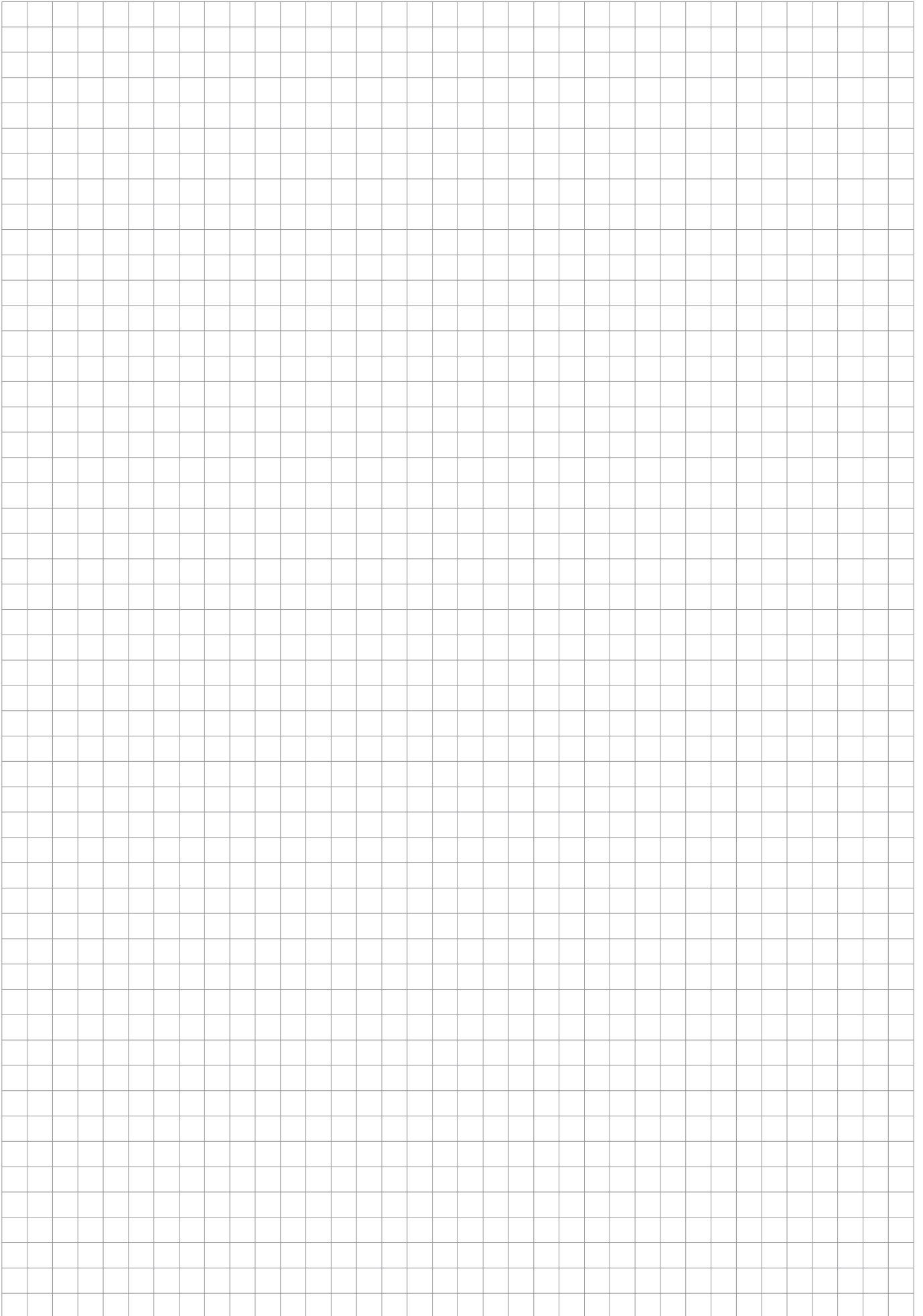

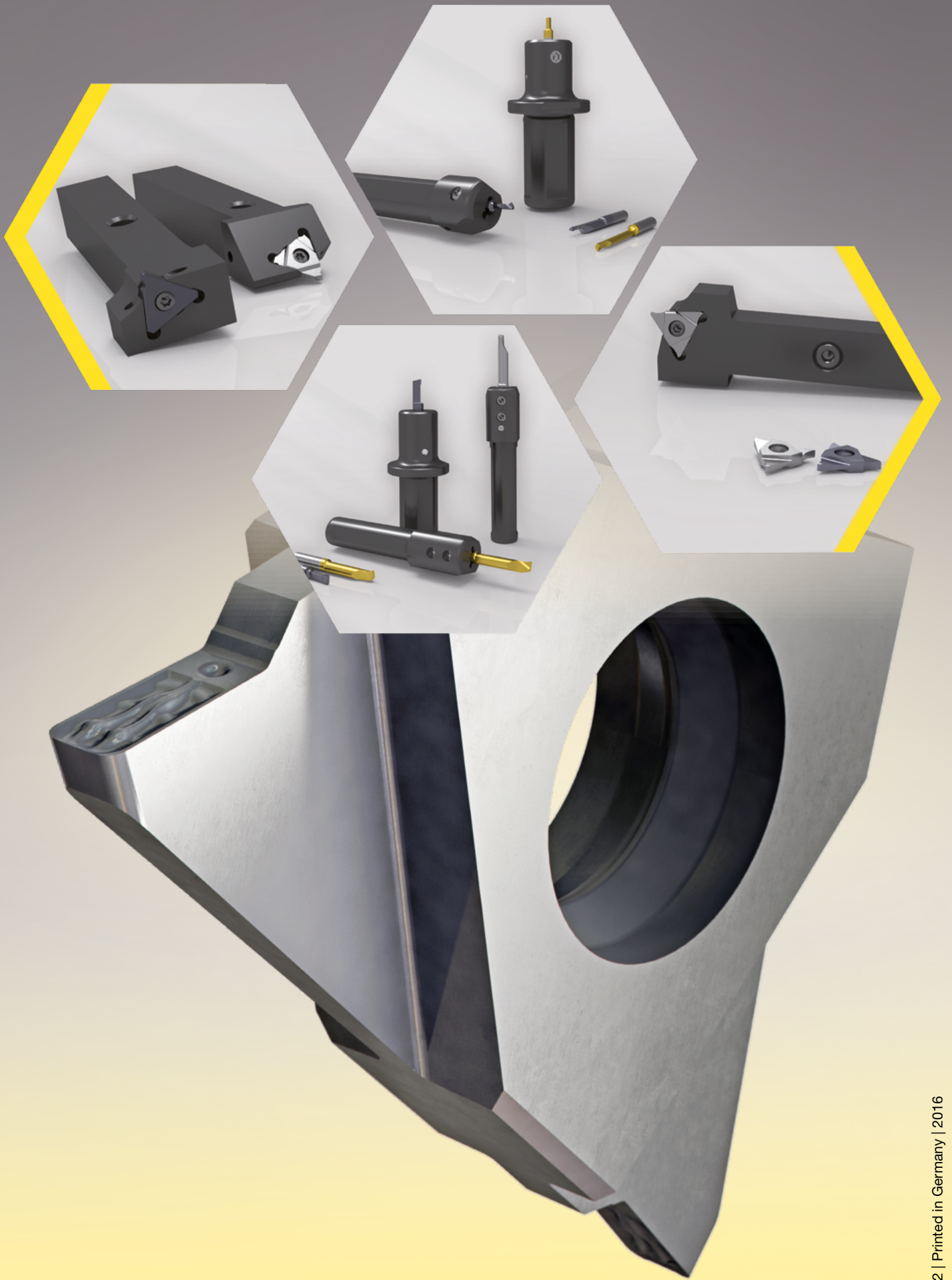

GUHRING KG | Tel.: + 49 74 31 17-0 | Fax: + 49 74 31 17-21279

Herderstrasse 50-54 | 72458 Albstadt | Germany | info@guehring.de | www.guehring.de